



Scan QR Code for More

Electric Pallet Truck PT20/25/30P-C

PARTS MANUAL

509046020101

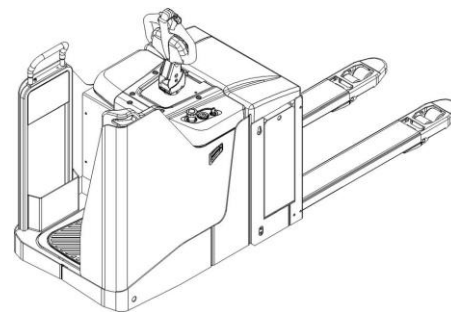
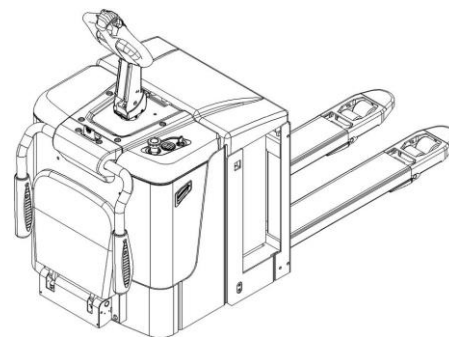

Version: V06

Truck Identification Number From:

Parts Manual

PT20/25/30P-C-PM06EN

Please order spare parts from authorized dealers of Noblelift Intelligent Equipment Co., LTD.

In order to avoid wrong delivery, all the orders for spare parts should specify the following items:

- Truck model, identification number and manufacture year.
- Orders for spare parts of mast, hydraulic transmission unit, steering axle, motor, etc. shall indicate the manufacture number of these parts.
- Codes for Noblelift spare parts are shown in the table of parts manual. Please also pay attention to the description of supply status, order quantity, etc. (check the number listed in "Mark" column of the parts manual).

"Mark" Column:

The unmarked indicates the parts are in short supply cycle.

Number 1: supply as package. Indicating these that parts are small parts and seal parts, which are supplied in package unit and in short supply cycle.

Number 2: supply with constraints. Indicating that these spare parts are not in stock and will be prepared for production after receiving the order from customers, which are in long supply cycle.

Number 3: phasing-out supply. Indicating that these parts will be replaced by new parts due to technical improvements and the current stock will not be available when these parts run out. Please check the description of technical improvements notice.

Number 4: supply as assembly. Indicating that these parts are assembly parts defined by manufacture process, which cannot be supplied as a single part.

Number 5: check other tables.

This parts manual is the property of Noblelift and can be shared under the confidential agreement only, Noblelift has the right to claim for compensation of any unauthorized use. Copy without permission is not allowed. Figures in the manual are not limited by the original design. Noblelift Intelligent Equipment Co., LTD reserves the right to improve the products for continuous technology progress.

Table of Contents

Chapter 1: Drive System.....	5
01 Drive Unit-Manual Steering (509046013501).....	5
01 Drive Unit-Manual Steering (509046013501) Continuation	7
02 Drive Assembly-Manual Steering (509046013001)	9
03 Drive Unit-EPS, Foldable (509046013502).....	11
03 Drive Unit-EPS, Foldable (509046013502) Continuation.....	13
04 Drive Assembly 2.0t,2.5t (509046013002).....	15
04 Drive Assembly 2.0t,2.5t (509046013002) Continuation	17
05 Drive Unit-EPS, Fixed (509046013503)	19
05 Drive Unit-EPS, Fixed (509046013503) Continuation.....	21
06 Drive Assembly 3.0t (509046013003).....	23
06 Drive Assembly 3.0t (509046013003) Continuation	25
Chapter 2: Hydraulic System.....	27
01 Hydraulic Components 2.0t (509046024001).....	27
02 Hydraulic Unit (505646023501).....	29
03 Hydraulic Components 2.5t,3.0t (509546024001).....	31
04 Hydraulic Unit (506946024002).....	33
Chapter 3: Truck Frame	35
01 Truck Frame, Foldable (509046021501)	35
01 Truck Frame, Foldable (509046021501) Continuation.....	37
02 Truck Frame, Foldable (509046021502)	39
03 Truck Frame, Fixed (509046021503)	41
03 Truck Frame, Fixed (509046021503) Continuation.....	43
03 Truck Frame, Fixed (509046021503) Continuation.....	45
Chapter 4:Chassis	47
01 Chassis (509046038501).....	47
01 Chassis (509046038501) Continuation.....	49
Chapter 5: Steering System, Braking System, Wheels	51
01 Tiller Unit (505646011001)	51
02 Control Handle (505646011003).....	53
03 Load Wheel (Tandem) (505646017001).....	55
04 Control Handle, Fixed (509046011001)	57
05 Caster 2.0t,2.5t,3.0t (509046016501)	59
06 Caster (2.0t specific type) (509046016502).....	61
07 Control Handle, detong (505646011002)	63
Chapter 6: Electrical Parts	67
01 Display Assembly (509046010001).....	67
02 Charger, Lead acid (509046036501).....	69
03 Charger, Lithium battery (509046036502).....	71
04 Lead acid (509046037001)	73
05 Lead acid (509046037002)	75
06 Lithium battery (509046037003).....	77

07 Lithium battery (509046037004).....	79
08 Controller, F2A +1220C (509046033001).....	81
08 Controller, F2A +1220C (509046033001) Continuation.....	83
09 Controller, 1232E (509046033002).....	85
09 Controller, 1232E (509046033002) Continuation.....	87
10 Controller, 1232E +1220C (509046033003).....	89
10 Controller, 1232E +1220C (509046033003) Continuation.....	91
11 Controller, QT (509046033004).....	93
11 Controller, QT (509046033004) Continuation.....	95
12 Wire Harness, F2A +1220C (509046033005).....	97
13 Wire Harness, 1232E+Li (509046033006).....	99
14 Wire Harness, QT (509046033001).....	101
15 Wire Harness, 1232E+1220C+ Fixed (509546033001).....	103
Chapter 7: Special Parts.....	105
01 Guard Arm (505646017501).....	105
02 Platform (505646018001).....	107
02 Platform (505646018001) Continuation.....	109
Chapter 8: Others.....	111
01 Labels, Decals-EU (509046047001).....	111
02 Labels, Decals-US (509046047002).....	113
03 Labels, Decals-EU, Fixed (509046047003).....	115
04 Labels, Decals-US, Fixed (509046047004).....	117
Appendix.....	119
01 Hydraulic Circuit Diagram (509046045501).....	119
02 Electrical Circuit Diagram, F2A +1220C (509046045501).....	120
03 Electrical Circuit Diagram, 1232E+Li (509046045502).....	121
04 Electrical Circuit Diagram, QT (509046045503).....	122
05 Electrical Circuit Diagram, QT+Li (509046045504).....	123
06 Electrical Circuit Diagram, 1232E+1220C+ Fixed (509546045501).....	124
07 Electrical Circuit Diagram, 1232E+1220C+ Foldable (509546045502).....	125
08 Electrical Circuit Diagram, 1232E+1220C+ Fixed +Li(509546045503).....	126
09 Electrical Circuit Diagram, 1232E+1220C+ Foldable +Li(509546045504).....	127
10 Consumable Parts List.....	128

Chapter 1: Drive System

01 Drive Unit-Manual Steering (509046013501)

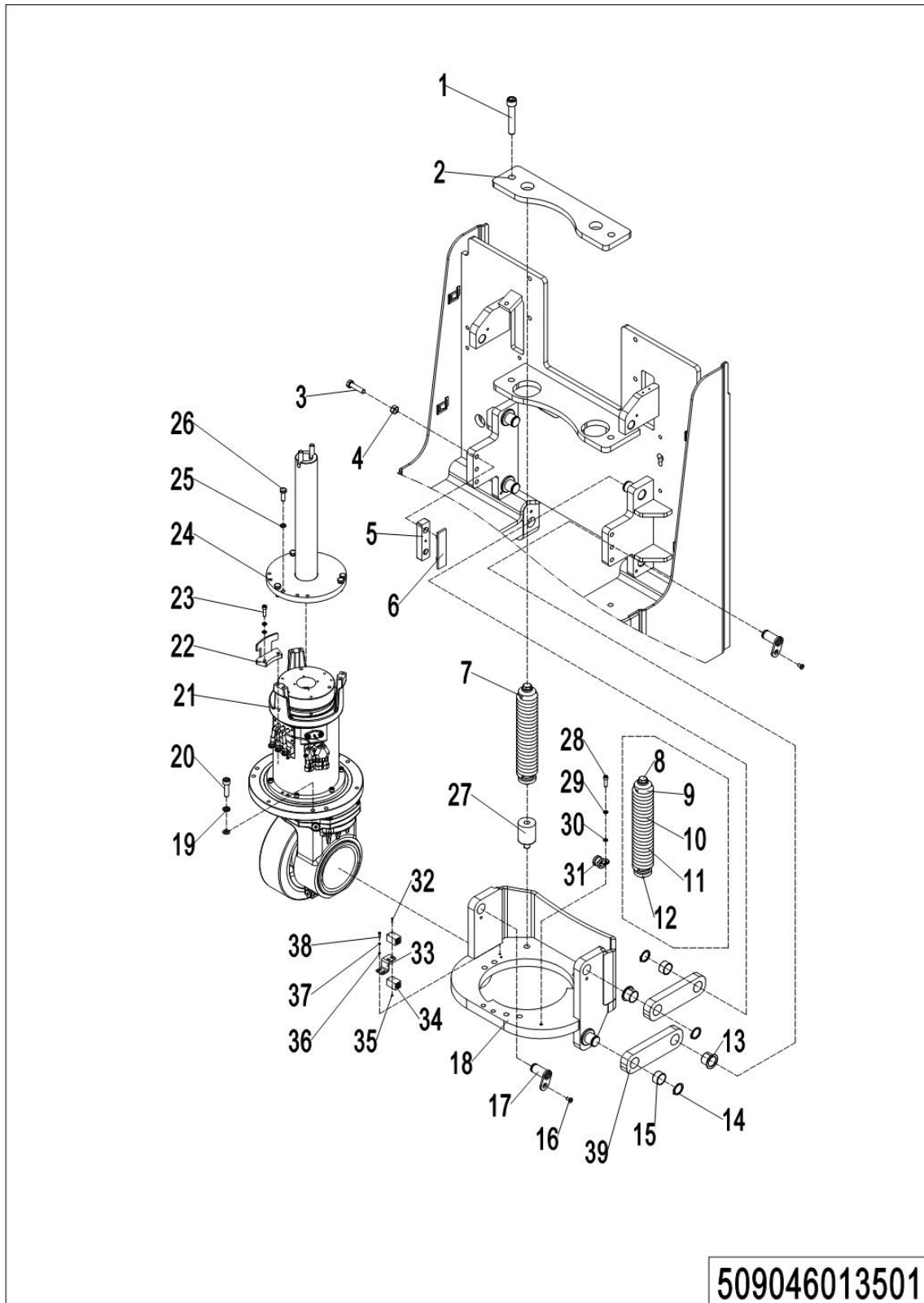

1=整包供货

2=限制供货

3=逐渐停止供货

4=不单件供货

5=见另外表单

01 Drive Unit-Manual Steering (509046013501)

No.	Item Code	Mark	Item Description	Qty.	Substitute	Note
1	910100100068		Bolt	2		
2	509013520003		Top Plate	1		
3	910100300041		Bolt	6		
4	910300100007		Nut	6		
5	509013520006		Mounting Plate	2		
6	509013520008		Subplate	2		
7	532613510001		Spring Components	2		
7	505913510003		Spring Components	2		
8	941100200001		Bolt	2		
9	532613520004		Gland	2		
10	532613520002		Spring	2		
10	505913520006		Spring	2		
11	532613520003		Sleeve	2		
12	532613520001		Guide Rail	2		
13	940500200010		Bushing	4		
14	910401300014		Circlip	6		
15	940500100027		Bushing	4		
16	910200400016		Screw	4		
17	509013510001		Pin	4		
18	509013510000		Bracket	1		
19	910400500007		Spring Washer	6		
20	910200200080		Screw	6		
21	961000900000		Drive Assembly	1		See 509046013001
22	509013530001		Stop Plate	1		
23	910200200036		Screw	2		
24	509031230000		handle Spindle	1		
25	910100300023		Bolt	6		
26	910400500006		Spring Washer	6		
27	532613520014		Subplate	2		
28	910200200033		Screw	1		

1=整包供货

2=限制供货

3=逐渐停止供货

4=不单件供货

5=见另外表单

01 Drive Unit-Manual Steering (509046013501) Continuation

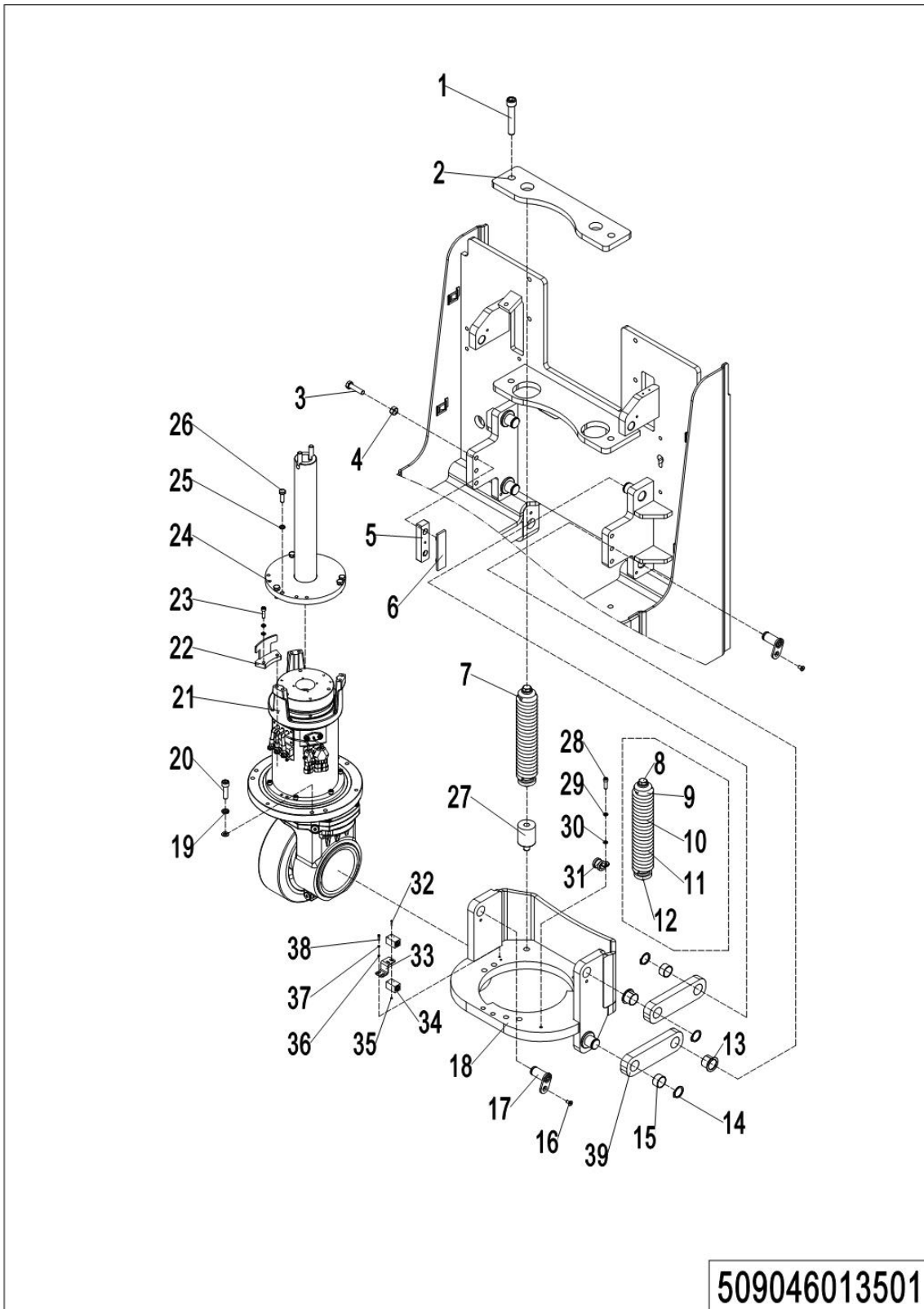

1=整包供货

2=限制供货

3=逐渐停止供货

4=不单件供货

5=见另外表单

01 Drive Unit-Manual Steering (509046013501) Continuation

No.	Item Code	Mark	Item Description	Qty.	Substitute	Note
29	910400500005		Spring Washer	3		
30	910400100005		Flat Washer	3		
31	951000100003		Hose Clamp	1		
32	910200500018		Screw	2		
33	509013540006		Mounting Plate	1		
34	502311010001		Proximity Switch	2		
35	910300500011		Nut	2		
36	910400100003		Flat Washer	2		
37	910400500003		Spring Washer	2		
38	910200200014		Screw	2		
39	509013520004		Rod	4		

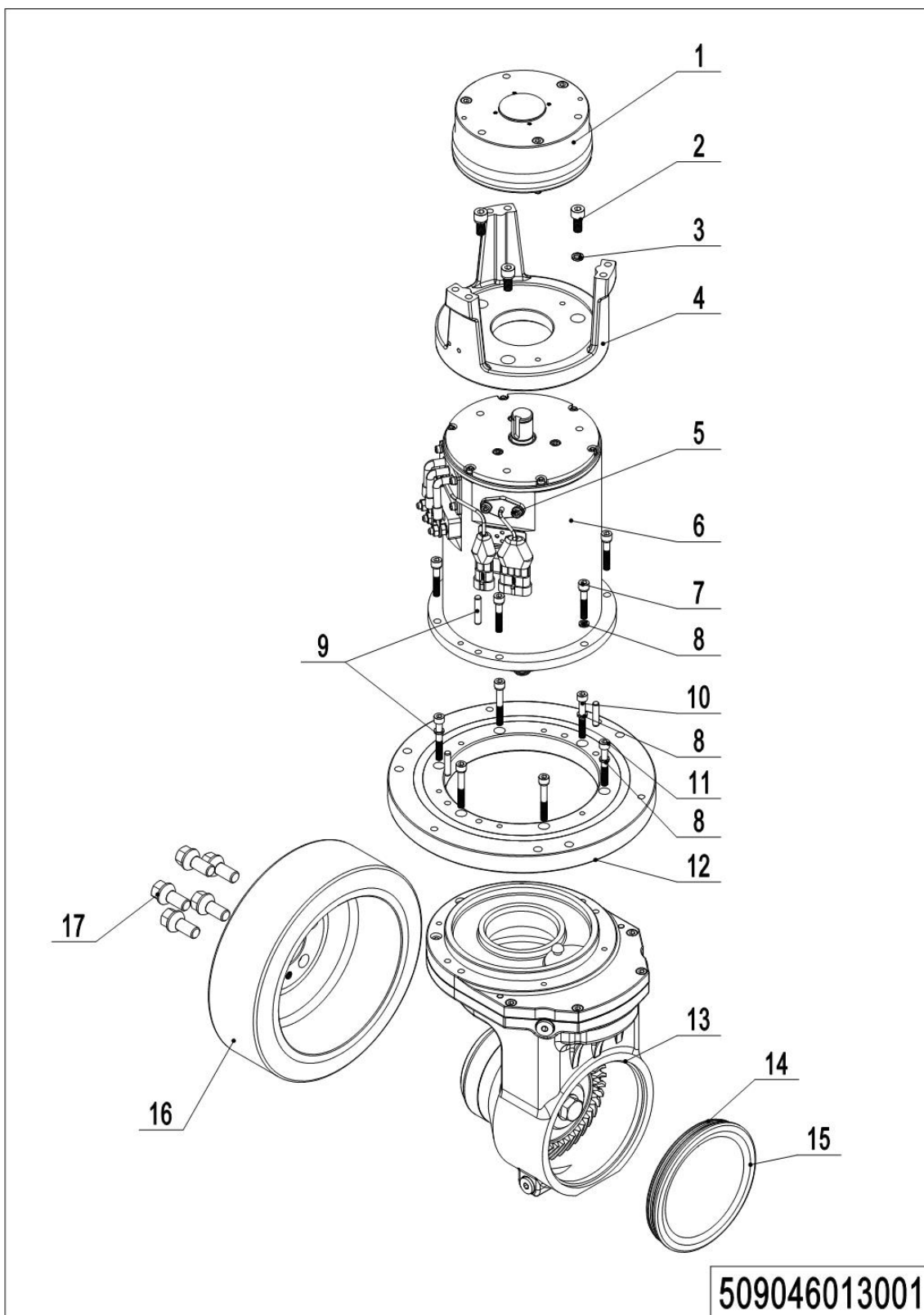
02 Drive Assembly-Manual Steering (509046013001)

1=整包供货

2=限制供货

3=逐渐停止供货

4=不单件供货

5=见另外表单

02 Drive Assembly-Manual Steering (509046013001)

No.	Item Code	Mark	Item Description	Qty.	Substitute	Note
1	961000400001		Brake	1		
2	910200200149		Screw	3		
3	910400500019		Spring Washer	3		
4	961000400002		Holder	1		
5	961000900002		Encoder	1		
6	961000900001		Motor	1		
7	910200200143		Screw	1		
8	910400500018		Spring Washer	6		
9	910600100016		Cylindrical Pin	12		
10	910200200044		Screw	4		
11	910200200140		Screw	2		
12	961000400004		Slewing Bearing	4		
13	961000401000		Gear Unit	1		
14	940998520018		Side Cap	1		
15	910800100095		O-Ring	2		
16	961000300001		WheelΦ230x75	1		
17	940998520029		Screw	5		

03 Drive Unit-EPS, Foldable (509046013502)

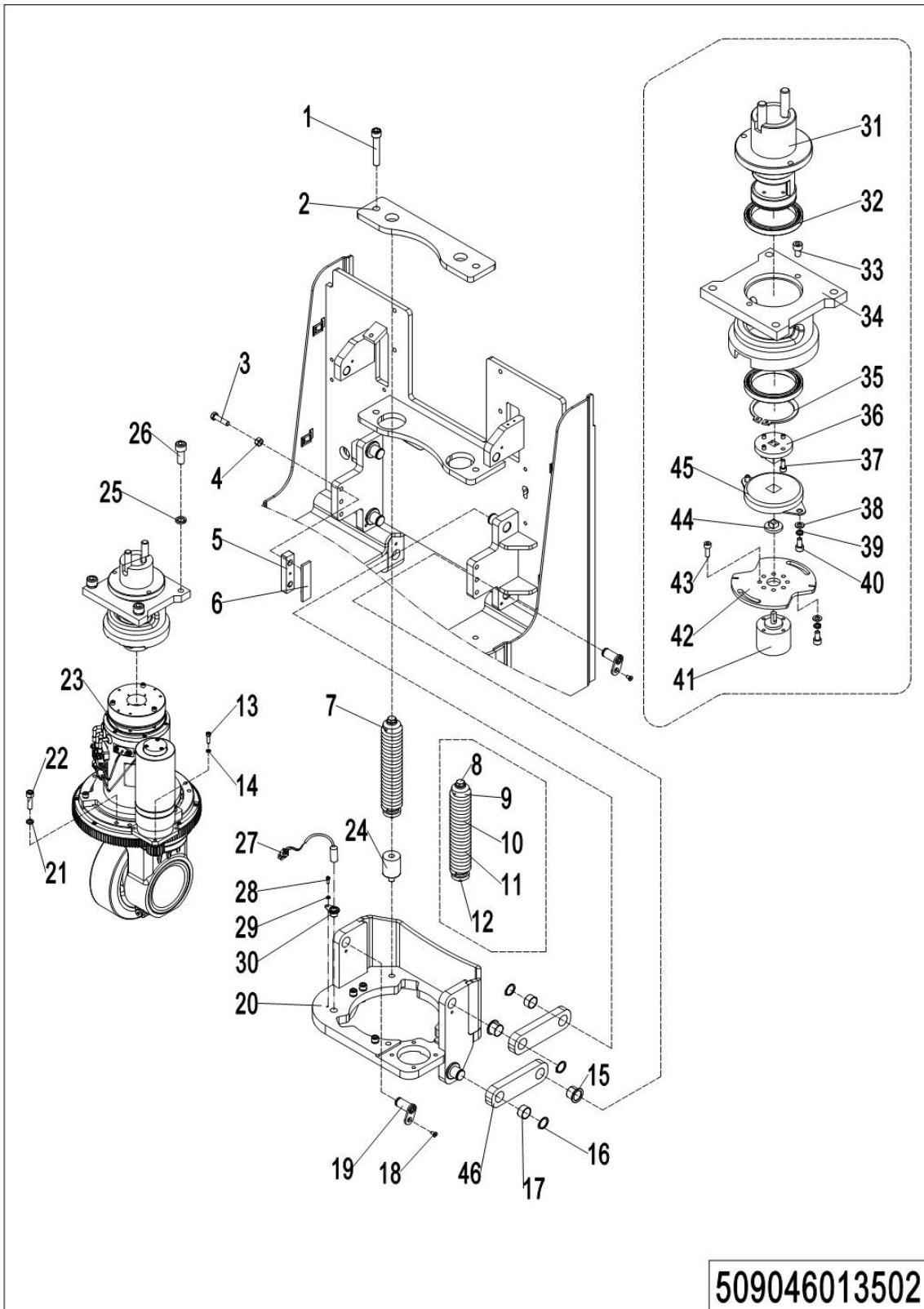

1=整包供货

2=限制供货

3=逐渐停止供货

4=不单件供货

5=见另外表单

03 Drive Unit-EPs, Foldable (509046013502)

No.	Item Code	Mark	Item Description	Qty.	Substitute	Note
1	91010010006		Bolt	2		
2	50901352000		Top Plate	1		
3	91010030004		Bolt	6		
4	91030010000		Nut	6		
5	50901352000		Mounting Plate	2		
6	50901352000		Subplate	2		
7	53261351000		Spring Components	2		
7	50591351000		Spring Components	2		
8	94110020000		Bolt	2		
9	53261352000		Gland	2		
10	53261352000		Spring	2		
10	50591352000		Spring	2		
11	53261352000		Sleeve	2		
12	53261352000		Guide Rail	2		
13	91020020005		Screw	4		
14	91040050000		Spring Washer	4		
15	94050020001		Bushing	4		
16	91040130001		Circlip	6		
17	94050010002		Bushing	4		
18	91020040001		Screw	4		
19	50901351000		Pin	4		
20	50901351000		Bracket	1		
21	91040050000		Spring Washer	6		
22	91020020007		Screw	6		
23	940900500016		Drive Assembly	1		See 509046013002
23	940900500025		Drive Assembly			See 509046013003
24	532613520014		Subplate	2		
25	910400100007		Flat Washer	4		
26	910200200075		Screw	4		
27	506733510006		Proximity Switch	1		

1=整包供货

2=限制供货

3=逐渐停止供货

4=不单件供货

5=见另外表单

03 Drive Unit-EPS, Foldable (509046013502) Continuation

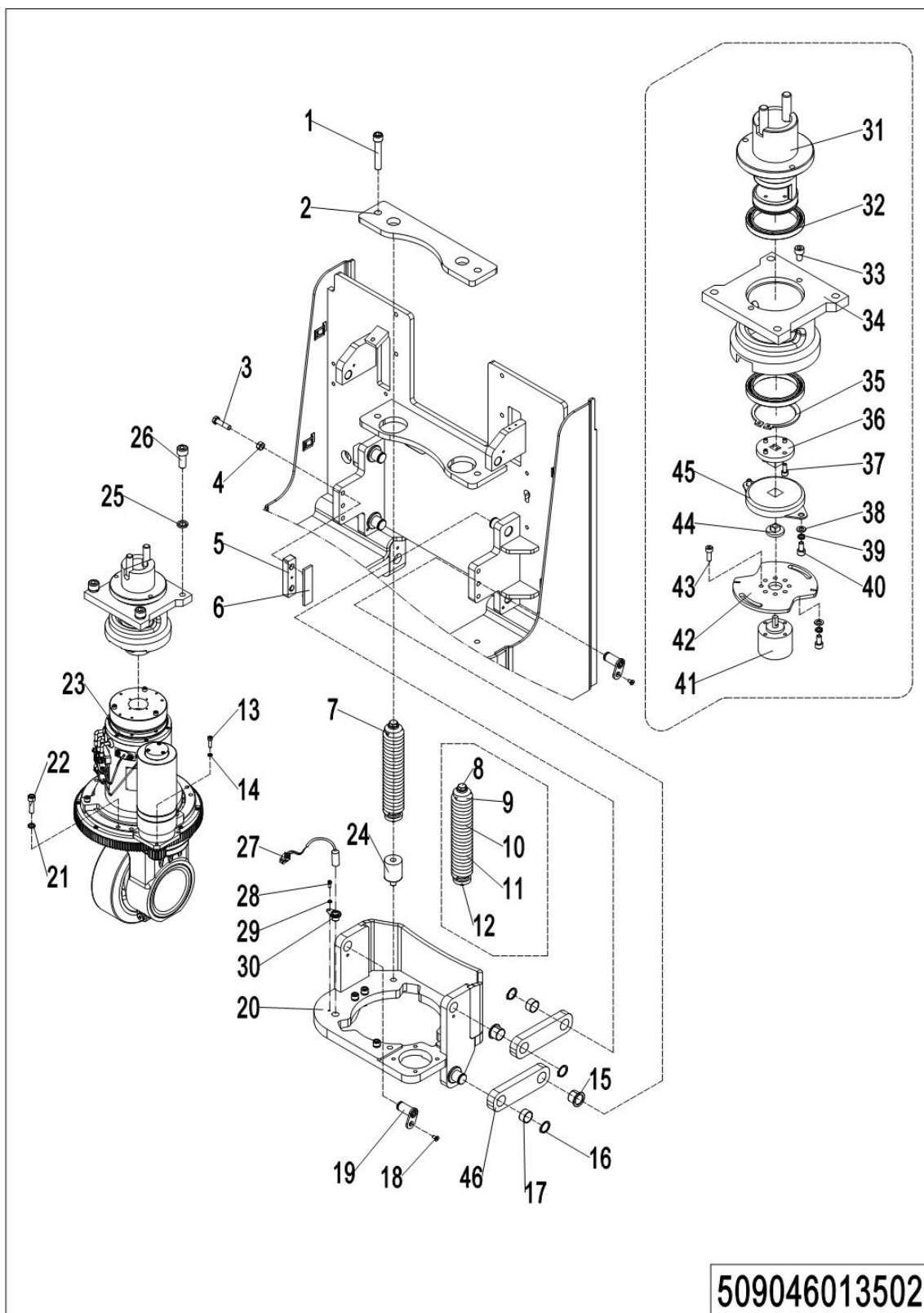

1=整包供货

2=限制供货

3=逐渐停止供货

4=不单件供货

5=见另外表单

03 Drive Unit-EPS, Foldable (509046013502) Continuation

No.	Item Code	Mark	Item Description	Qty.	Substitute	Note
28	91020020001		Screw	1		
29	91040050000		Spring Washer	1		
30	533213510005		Bushing	1		
31	505631510001		Bracket	1		
32	910700200041	1	Bearing	2		
33	910200200032	1	Screw	3		
34	505631520002		Fixing Base	1		
35	910401300024	1	Circlip	1		
36	505631520005		Link Block	1		
37	910200500022	1	Screw	4		
38	910400100004	1	Flat Washer	4		
39	910400500004	1	Spring Washer	4		
40	910200200022	1	Screw	4		
41	921800200006		Potentiometer	1		
42	505731520001		Fixing Plate	1		
43	910200200014	1	Screw	4		
44	505631520003		Link Block	1		
45	940801200001		Rotary Damper	1		
46	509013520004		Rod	4		

04 Drive Assembly 2.0t,2.5t (509046013002)

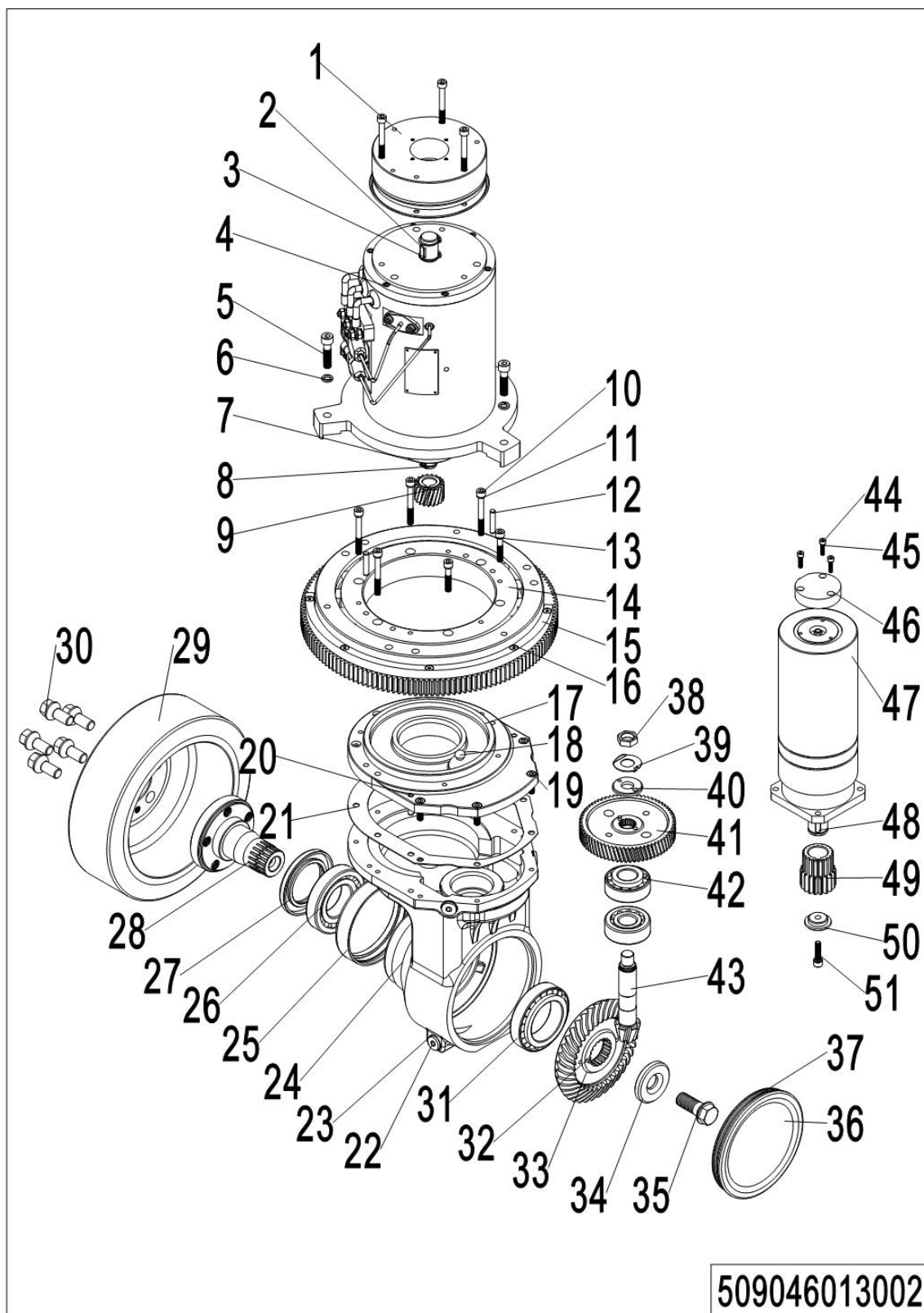

1=整包供货

2=限制供货

3=逐渐停止供货

4=不单件供货

5=见另外表单

04 Drive Assembly 2.0t,2.5t (509046013002)

No.	Item Code	Mark	Item Description	Qty.	Substitute	Note
1	961000400001		Brake	1		
2	910600800012		Flat Key	1		
3	910401300011		Circlip	2		
4	961000500001		Motor	1		
5	910200200144		Screw	3		
6	910400500019		Spring Washer	3		
7	910600800007		Flat Key	1		
8	910401300007		Circlip	1		
9	961000400005		Gear	1		
10	910200200049		Screw	4		
11	910400500018		Spring Washer	14		
12	910600100016		Cylindrical Pin	2		
13	910200200141		Screw	2		
14	961000500002		Gear	1		
15	961000500004		Induction Block	1		
16	910200400041		Screw	5		
17	961000400007		Cover	1		
18	940998510011		Screw Plug	1		
19	910200200139		Screw	7		
20	910600100039		Cylindrical Pin	2		
21	940998520025		Pad	1		
22	940998520042		Screw Plug	3		
23	910800900007		Bonded Washer	3		
24	961000400008		Gearbox	1		
25	940998520030		Dust Cover	1		
26	910700600040		Bearing	1		
27	940998520040		Oil Seal	1		
28	940998520026		Drive Shaft	1		
29	961000300001		WheelΦ230x75	1		
30	940998520029		Screw	5		

1=整包供货

2=限制供货

3=逐渐停止供货

4=不单件供货

5=见另外表单

04 Drive Assembly 2.0t,2.5t (509046013002) Continuation

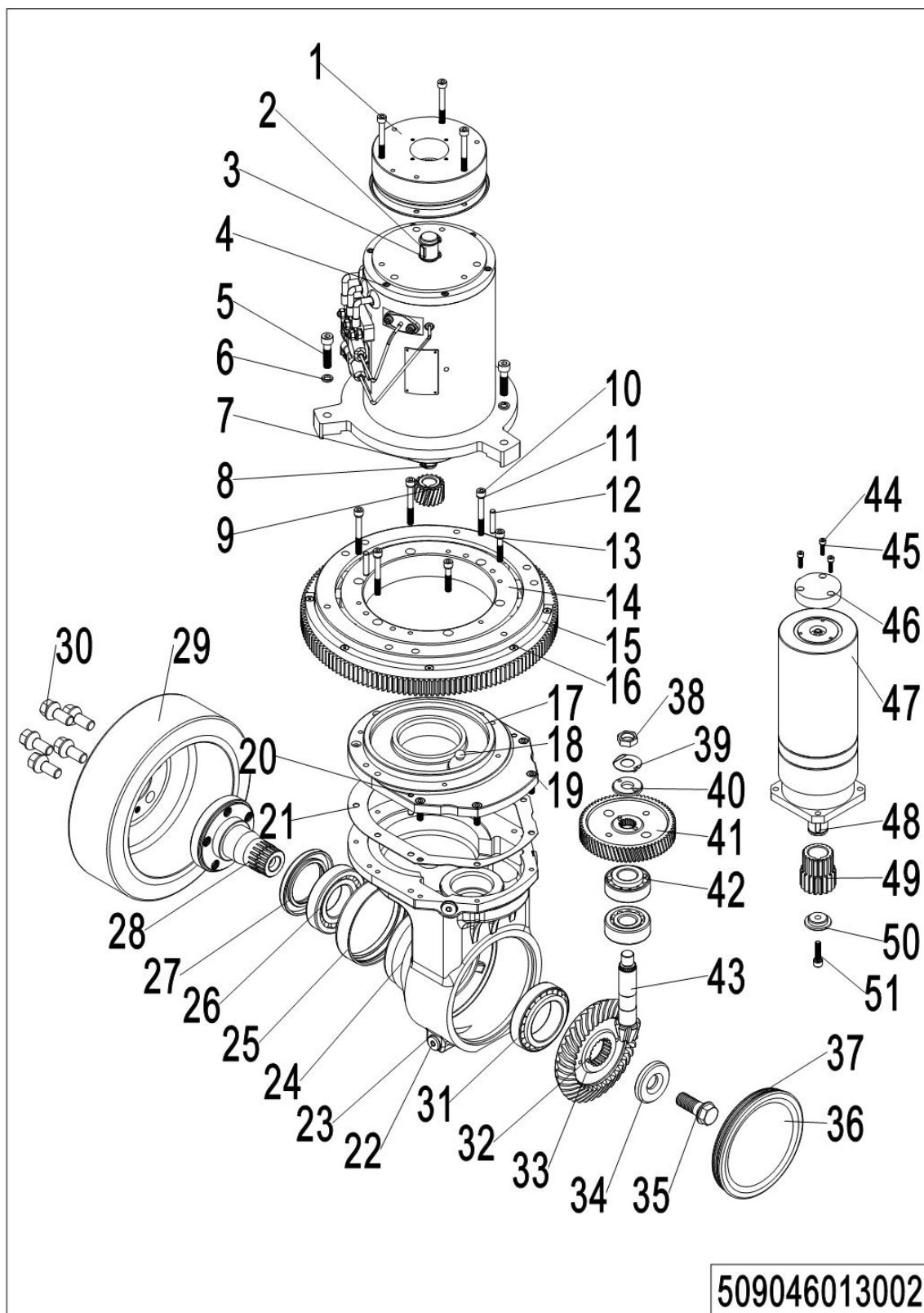

1=整包供货

2=限制供货

3=逐渐停止供货

4=不单件供货

5=见另外表单

04 Drive Assembly 2.0t,2.5t (509046013002) Continuation

No.	Item Code	Mark	Item Description	Qty.	Substitute	Note
31	91070060004		Bearing	1		
32	91060010003		Cylindrical Pin	2		
33	94099852001		Gear	1		
34	94099852002		Circlip	1		
35	94099852002		Lock Bolt	1		
36	94099852001		Side Cap	1		
37	91080010009		O-Ring	2		
38	91030040001		Nut	1		
39	91040100000		Lock Washer	1		
40	94099852003		Washer	1		
41	96100040000		Gear	1		
42	91070060004		Bearing	2		
43	94099852001		Gear	1		
44	91020020001		Screw	3		
45	91040050001		Spring Washer	3		
46	96100050000		Sensor	1		
47	96100050000		Steering Unit	1		
48	91060080001		Flat Key	1		
49	96100050000		Gear	1		
50	96100050000		Retaining Ring	1		
51	91020020014		Screw	1		

05 Drive Unit-EPS, Fixed (509046013503)

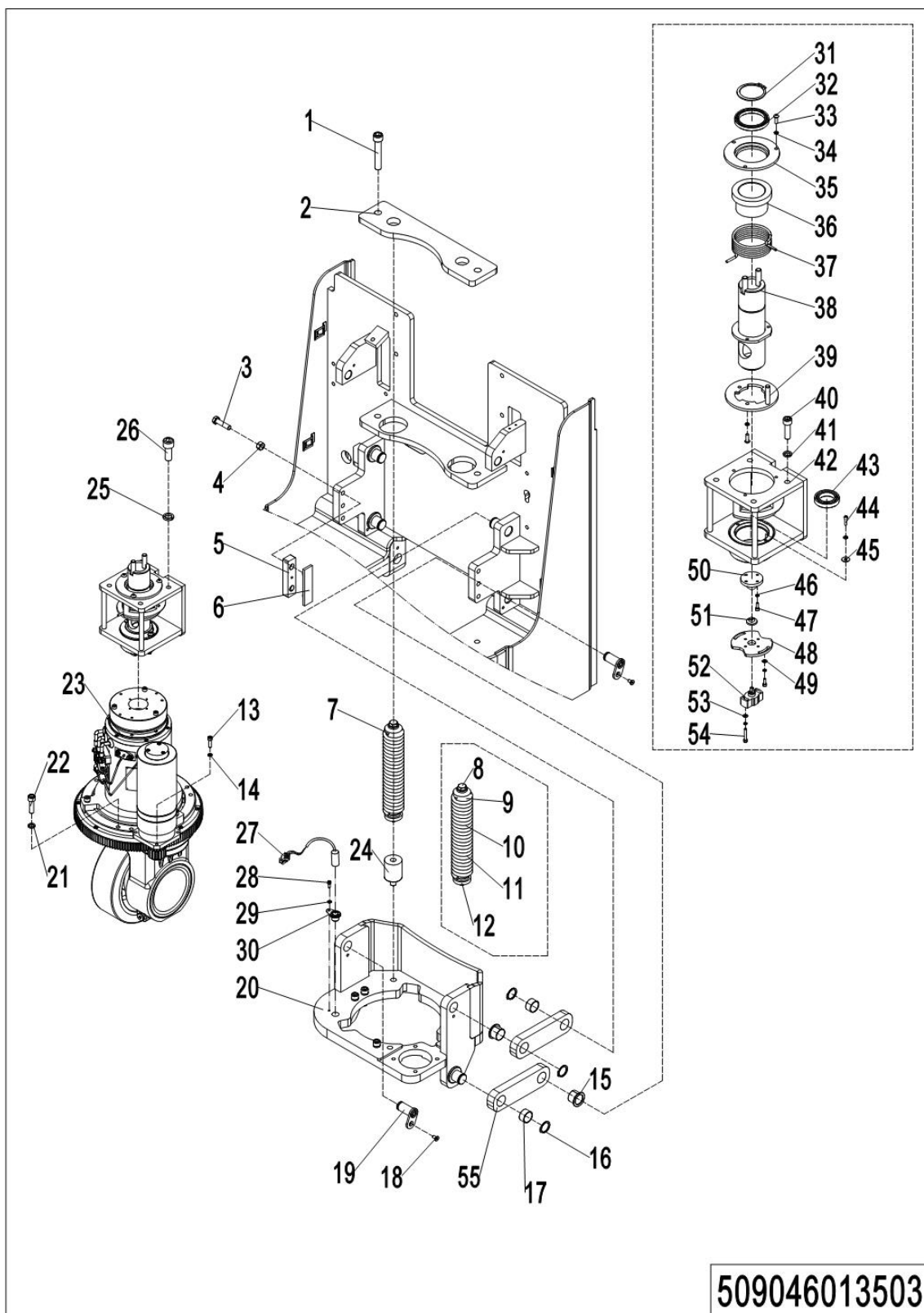

509046013503

1=整包供货

2=限制供货

3=逐渐停止供货

4=不单件供货

5=见另外表单

05 Drive Unit-EPS, Fixed (509046013503)

No.	Item Code	Mark	Item Description	Qty.	Substitute	Note
1	91010010006		Bolt	2		
2	50901352000		Top Plate	1		
3	91010030004		Bolt	6		
4	91030010000		Nut	6		
5	50901352000		Mounting Plate	2		
6	50901352000		Subplate	2		
7	53261351000		Spring Components	2		
7	50591351000		Spring Components	2		
8	94110020000		Bolt	2		
9	53261352000		Gland	2		
10	53261352000		Spring	2		
10	50591352000		Spring	2		
11	53261352000		Sleeve	2		
12	53261352000		Guide Rail	2		
13	91020020005		Screw	4		
14	91040050000		Spring Washer	4		
15	94050020001		Bushing	4		
16	91040130001		Circlip	6		
17	94050010002		Bushing	4		
18	91020040001		Screw	4		
19	50901351000		Pin	4		
20	50901351000		Bracket	1		
21	91040050000		Spring Washer	6		
22	91020020007		Screw	6		
23	940900500016		Drive Assembly	1		See 509046013002
23	940900500025		Drive Assembly			See 509046013003
24	532613520014		Subplate	2		
25	910400100007		Flat Washer	4		
26	910200200075		Screw	4		
27	506733510006		Proximity Switch	1		

1=整包供货

2=限制供货

3=逐渐停止供货

4=不单件供货

5=见另外表单

05 Drive Unit-EPS, Fixed (509046013503) Continuation

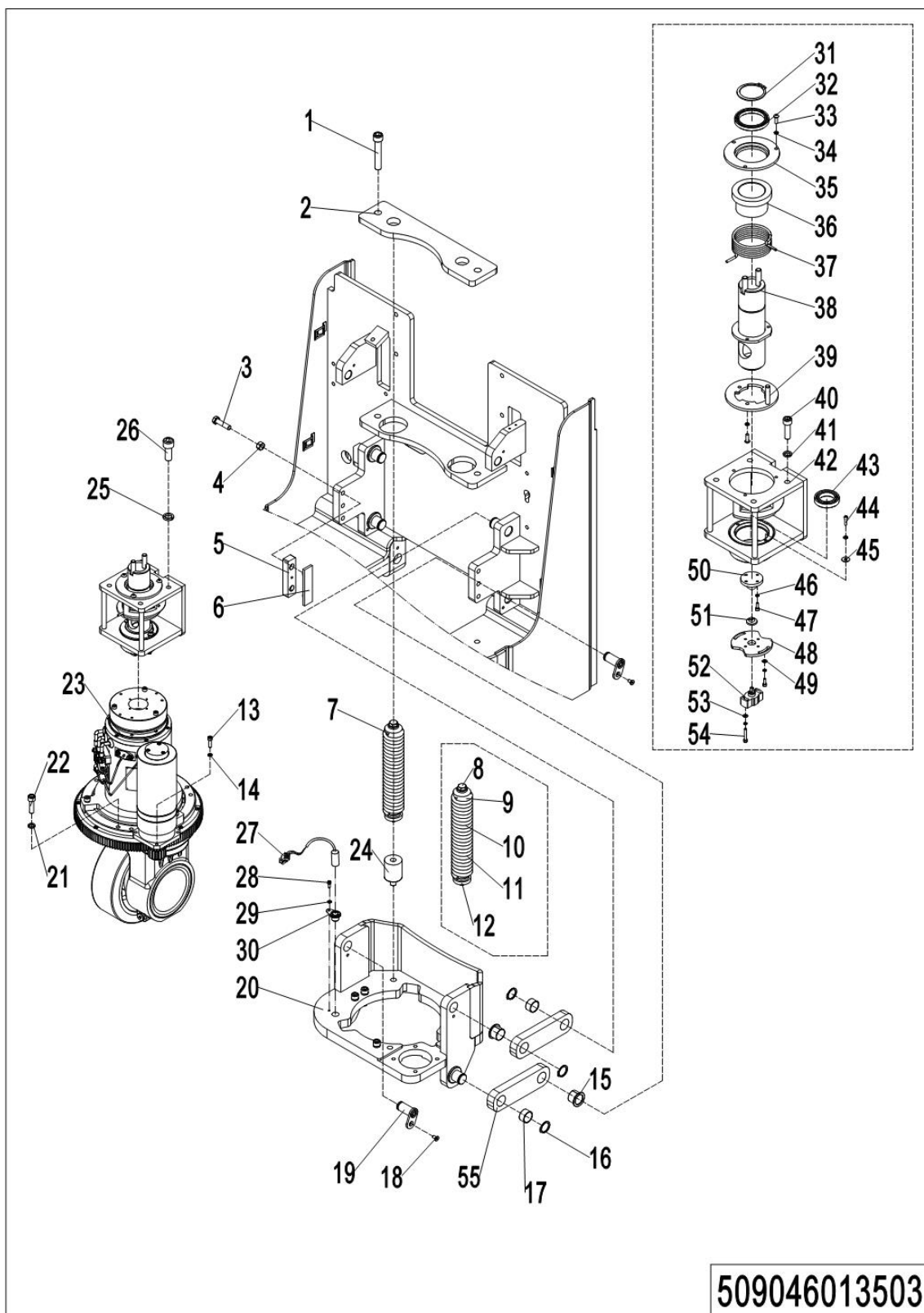

1=整包供货

2=限制供货

3=逐渐停止供货

4=不单件供货

5=见另外表单

05 Drive Unit-EPS, Fixed (509046013503) Continuation

No.	Item Code	Mark	Item Description	Qty.	Substitute	Note
28	91020020001		Screw	1		
29	910400500003		Spring Washer	1		
30	533213510005		Bushing	1		
31	910401300024		Circlip	1		
32	910700400006		Bearing	1		
33	910200300013		Screw	6		
34	910400500004		Spring Washer	8		
35	505931520014		Bracket	1		
36	505931520003		Nylon Sleeve	1		
37	940400700001		Spring	1		
38	509031510000		Axle	1		
39	509031510001		Positioning Plate	1		
40	910200200075		Screw	4		
41	910400500007		Spring Washer	4		
42	509031510002		Bracket	1		
43	910700200041		Bearing	1		
44	910200200023		Screw	2		
45	910400200001		Flat Washer	2		
46	910400500003		Spring Washer	6		
47	910200200014		Screw	6		
48	509031520001		Mounting Plate	1		
49	910400100003		Flat Washer	2		
50	505631520005		Link Block	1		
51	505631520003		Link Block	1		
52	921800200006		Potentiometer	1		
53	910400100004		Flat Washer	2		
54	910200200017		Screw	2		
55	509013520004		Rod	4		

06 Drive Assembly 3.0t (509046013003)

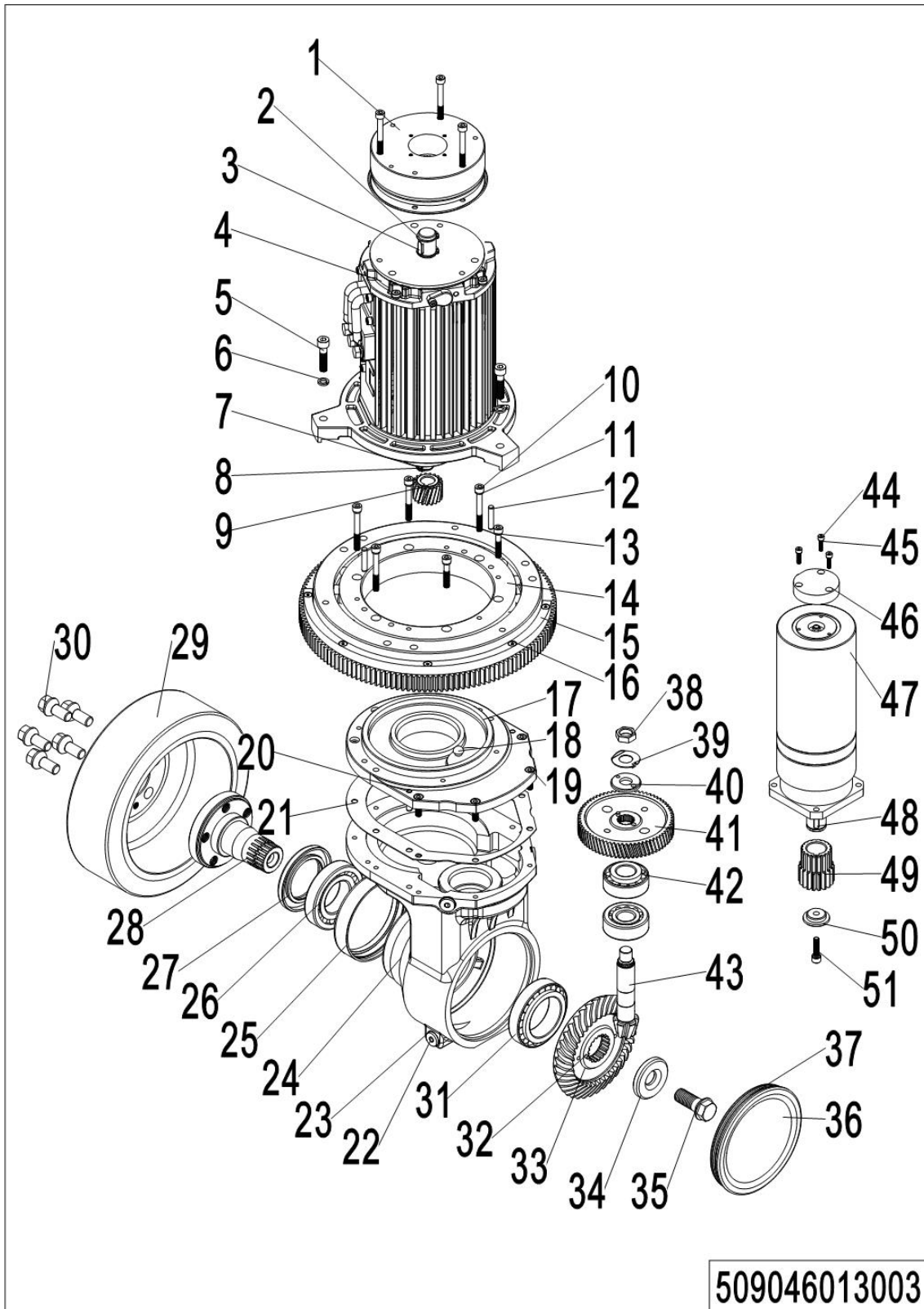

1=整包供货

2=限制供货

3=逐渐停止供货

4=不单件供货

5=见另外表单

06 Drive Assembly 3.0t (509046013003)

No.	Item Code	Mark	Item Description	Qty.	Substitute	Note
1	961000400001		Brake	1		
2	910600800012		Flat Key	1		
3	910401300011		Circlip	2		
4	961001900001		Motor	1		
5	910200200144		Screw	3		
6	910400500019		Spring Washer	3		
7	910600800007		Flat Key	1		
8	910401300007		Circlip	1		
9	961000400005		Gear	1		
10	910200200049		Screw	4		
11	910400500018		Spring Washer	14		
12	910600100016		Cylindrical Pin	2		
13	910200200141		Screw	2		
14	961000500002		Gear	1		
15	961000500004		Induction Block	1		
16	910200400041		Screw	5		
17	961000400007		Cover	1		
18	940998510011		Screw Plug	1		
19	910200200139		Screw	7		
20	910600100039		Cylindrical Pin	2		
21	940998520025		Pad	1		
22	940998520042		Screw Plug	3		
23	910800900007		Bonded Washer	3		
24	961000400008		Gearbox	1		
25	940998520030		Dust Cover	1		
26	910700600040		Bearing	1		
27	940998520040		Oil Seal	1		
28	940998520026		Drive Shaft	1		
29	961000300001		WheelΦ230x75	1		
30	940998520029		Screw	5		

1=整包供货

2=限制供货

3=逐渐停止供货

4=不单件供货

5=见另外表单

06 Drive Assembly 3.0t (509046013003) Continuation

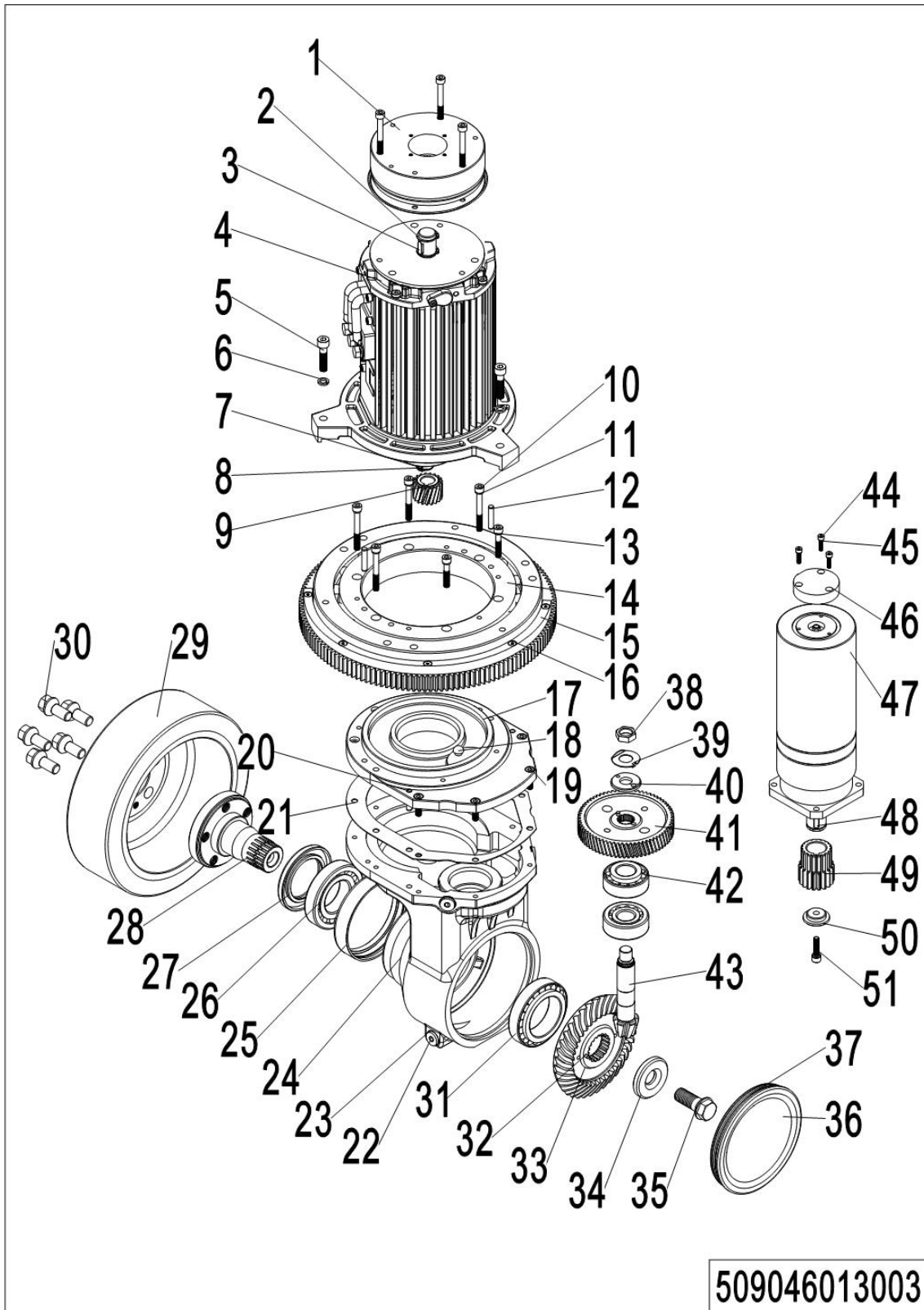

1=整包供货

2=限制供货

3=逐渐停止供货

4=不单件供货

5=见另外表单

06 Drive Assembly 3.0t (509046013003) Continuation

No.	Item Code	Mark	Item Description	Qty.	Substitute	Note
31	91070060004		Bearing	1		
32	91060010003		Cylindrical Pin	2		
33	94099852001		Gear	1		
34	94099852002		Circlip	1		
35	94099852002		Lock Bolt	1		
36	94099852001		Side Cap	1		
37	91080010009		O-Ring	2		
38	91030040001		Nut	1		
39	91040100000		Lock Washer	1		
40	94099852003		Washer	1		
41	96100040000		Gear	1		
42	91070060004		Bearing	2		
43	94099852001		Gear	1		
44	91020020001		Screw	3		
45	91040050001		Spring Washer	3		
46	96100050000		Sensor	1		
47	96100050000		Steering Unit	1		
48	91060080001		Flat Key	1		
49	96100050000		Gear	1		
50	96100050000		Retaining Ring	1		
51	91020020014		Screw	1		

Chapter 2: Hydraulic System

01 Hydraulic Components 2.0t (509046024001)

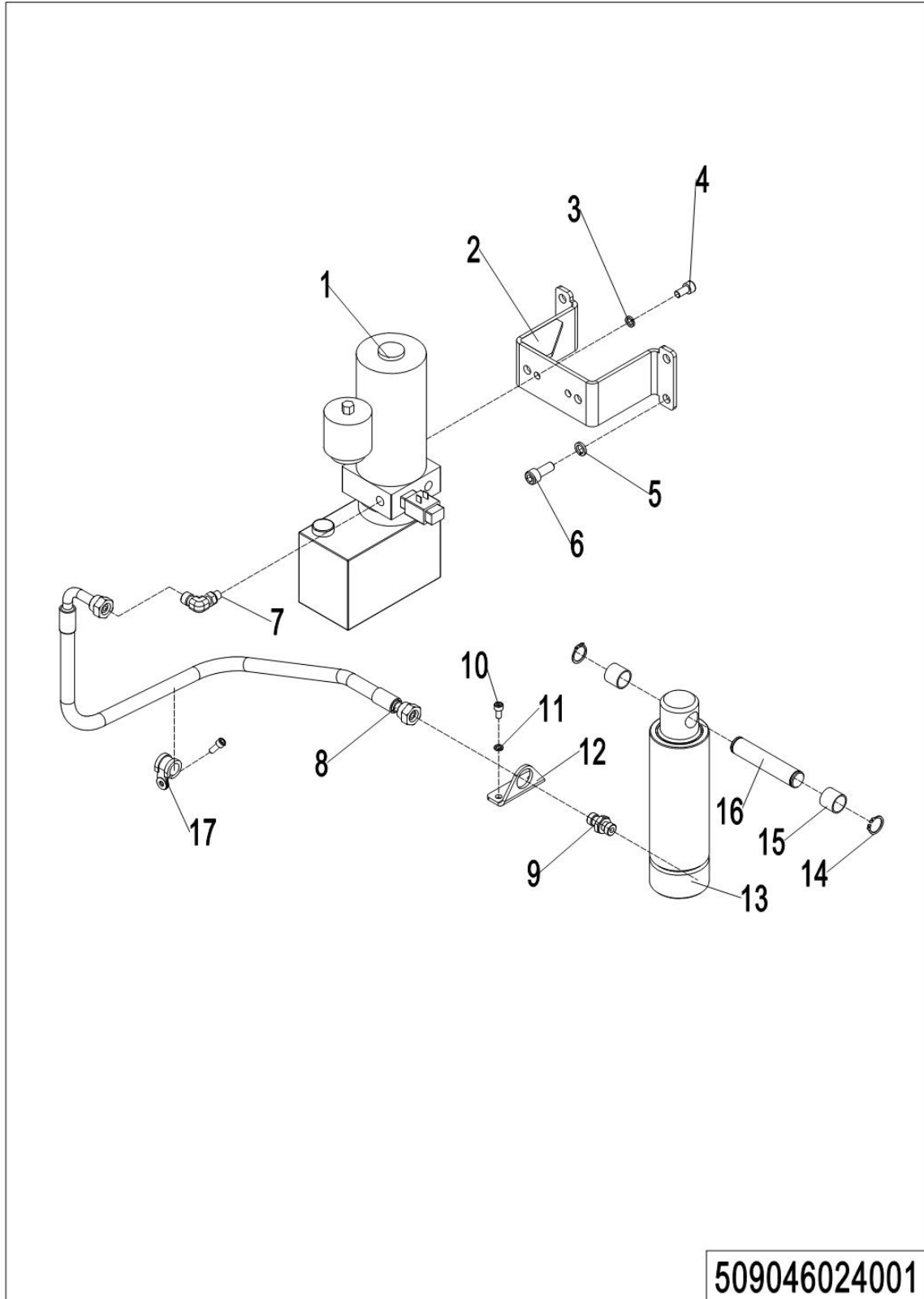

1=整包供货

2=限制供货

3=逐渐停止供货

4=不单件供货

5=见另外表单

01 Hydraulic Components (509046024001)

No.	Item Code	Mark	Item Description	Qty.	Substitute	Note
1	950900100036		Pump Unit	1		See 505646023501
2	509024010000		Mounting Plate	1		
3	910400500006		Spring Washer	2		
4	910200200055		Screw	2		
5	910400500007		Spring Washer	2		
6	910200200075		Screw	2		
7	950401100002		Joint	1		
8	509024020002		Hose	1		
9	950400400001		Joint	1		
10	910200200033		Screw	3		
11	910400500005		Spring Washer	2		
12	505621520027		Locating Rack	1		
13	505624010000		Cylinder	1		
14	910401300011		Circlip	2		
15	940500100019		Bushing	2		
16	505638520033		Pin	1		
17	951000100003		Hose Clamp	1		

02 Hydraulic Unit (505646023501)

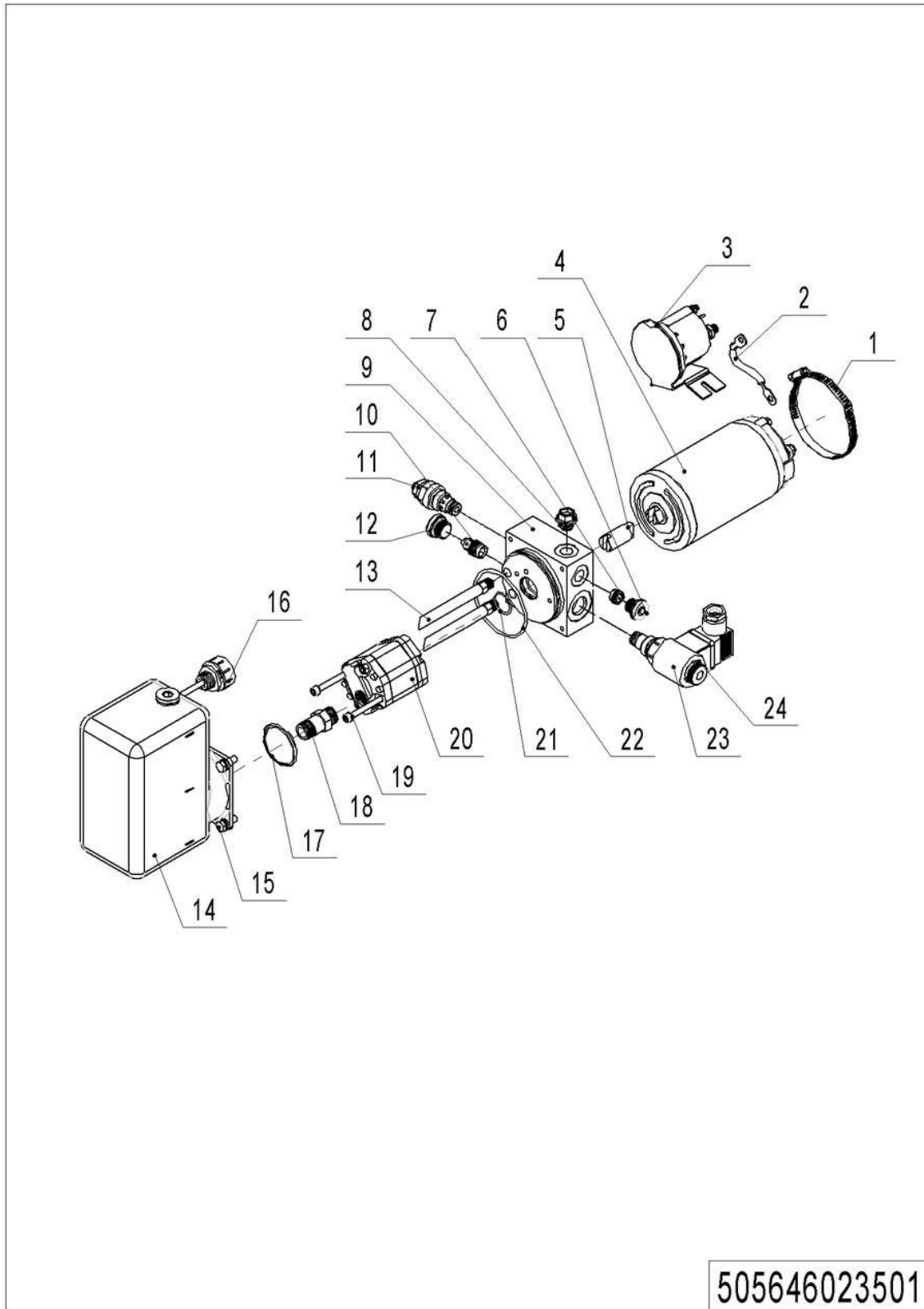

1=整包供货

2=限制供货

3=逐渐停止供货

4=不单件供货

5=见另外表单

02 Hydraulic Unit (505646023501)

No.	Item Code	Mark	Item Description	Qty.	Substitute	Note
1	505698520032		Hoop	1		
2	508098520007		Cables	1		
3	505698520034		Switch	1		
4	505698520035		Motor	1		
5	505698520036		Coupling	1		
6	505698520037		End Cap	1		
7	505698520038		Check Valve	1		
8	505698520039		End Cap	1		
9	505698520040		Valve Plate	1		
10	505698520041		Valve	1		
11	505698520042		Overflow Valve	1		
12	505698520043		End Cap	1		
13	505698520044		Pipe	2		
14	505698520045		Tank	1		
15	505698520046		Bolt	4		
16	505698520047		Cap-Tank	1		
17	505698520048		Filter	1		
18	505698520049		Oil Tube	1		
19	505698520050		Screw	2		
20	505698520051		Gear Pump	1		
21	505698520052		O-Ring	1		
22	505698520053		O-Ring	1		
23	505698520054		Magnetic Valve	1		
24	505698520055		Coil	1		

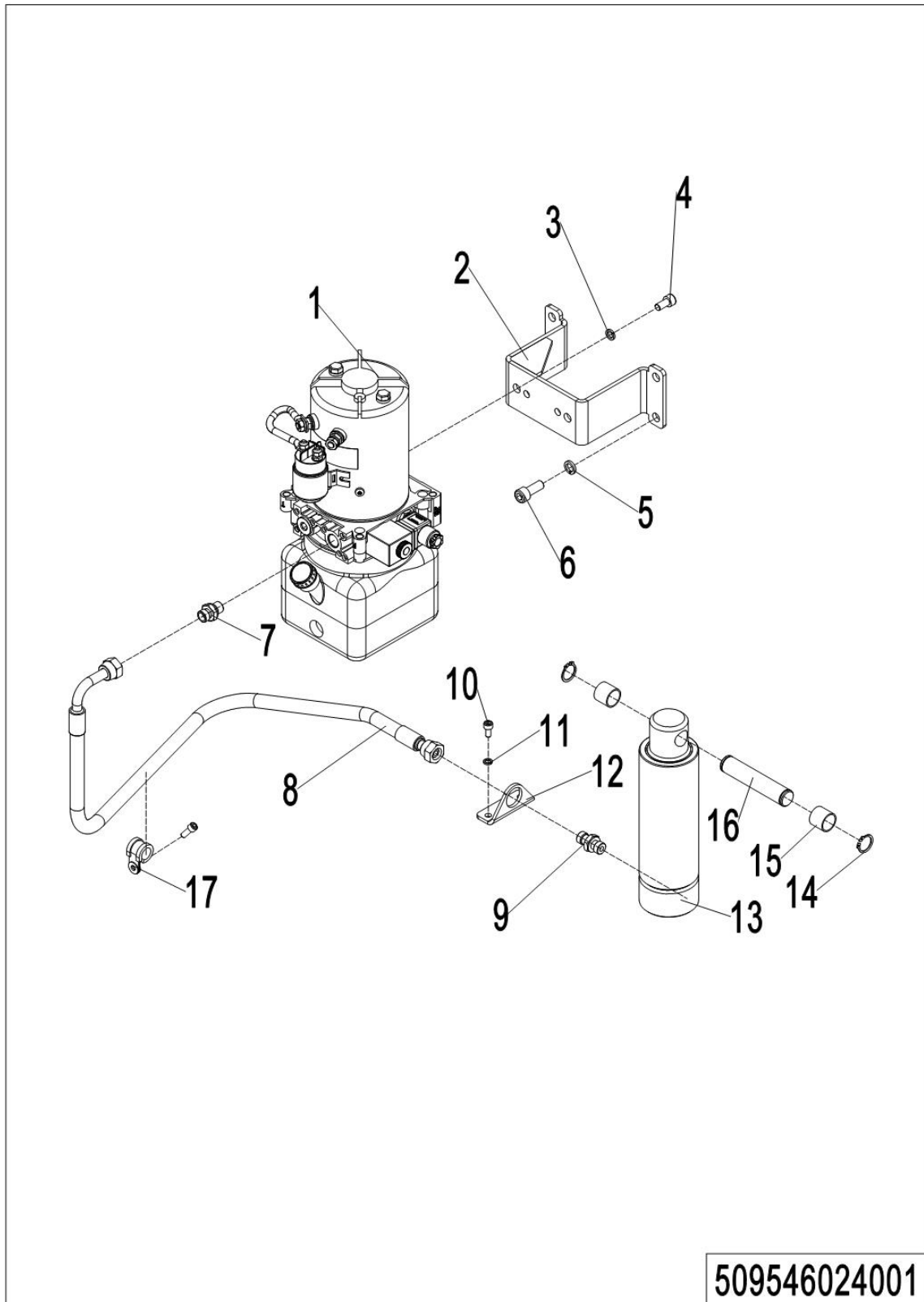
03 Hydraulic Components 2.5t,3.0t (509546024001)

1=整包供货

2=限制供货

3=逐渐停止供货

4=不单件供货

5=见另外表单

03 Hydraulic Components 2.5t, 3.0t (509546024001)

No.	Item Code	Mark	Item Description	Qty.	Substitute	Note
1	950900100024		Pump Unit	1		See 506946024002
2	509024010000		Mounting Plate	1		
3	910400500006		Spring Washer	2		
4	910200200055		Screw	2		
5	910400500007		Spring Washer	2		
6	910200200075		Screw	2		
7	950400300004		Joint	1		
8	509024020003		Hose	1		
9	950400400001		Joint	1		
10	910200200033		Screw	3		
11	910400500005		Spring Washer	2		
12	505621520027		Locating Rack	1		
13	505624010000		Cylinder	1		
14	910401300011		Circlip	2		
15	940500100019		Bushing	2		
16	505638520033		Pin	1		
17	951000100003		Hose Clamp	1		

04 Hydraulic Unit (506946024002)

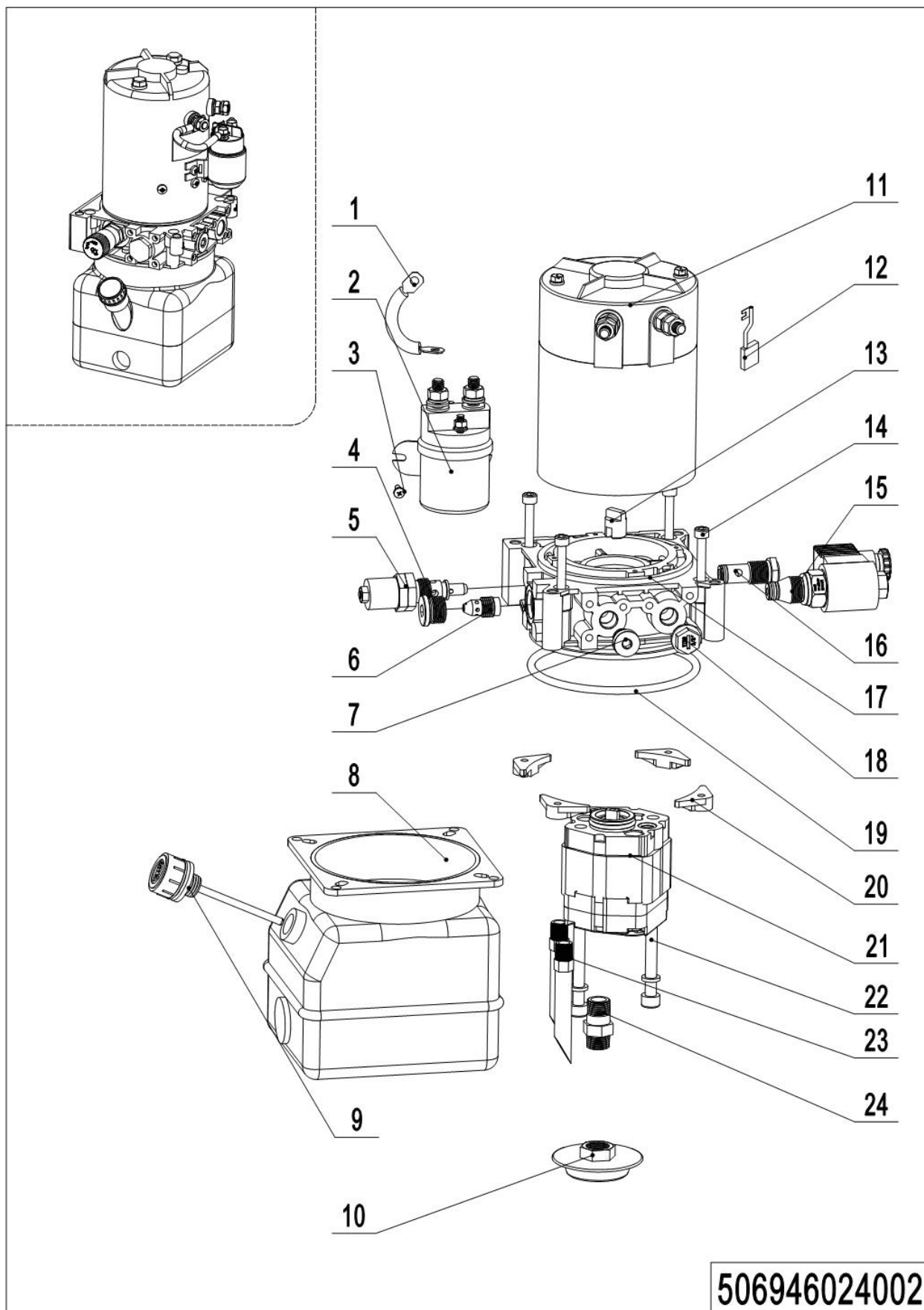

1=整包供货

2=限制供货

3=逐渐停止供货

4=不单件供货

5=见另外表单

04 Hydraulic Unit (506946024002)

No.	Item Code	Mark	Item Description	Qty.	Substitute	Note
--	950900100024		Pump Unit	1		
1	505798510004	2	Cables	1		
2	532098510002	2	Switch	1		
3	910200500036	1	Screw	1		
4	402698520020	2	Plug	1		
5	505798510007	2	Overflow Valve	1		
6	505798510006	2	Compensation Valve	1		
7	505798520014	2	End Cap	1		
8	505798520009	2	Tank	1		
9	505698520047	2	Cap-Tank	1		
10	402698520010	2	Filter	1		
11	532098510001	2	Motor	1		
12	505798510013	2	Carbon Brush	1		
13	505798520018	2	Coupling	1		
14	910200200042	1	Screw	4		
15	532098510006	2	Magnetic Valve	1		
16	505798510012	2	Check Valve	1		
17	505798520005	2	Valve Block	1		
18	505798520015	2	End Cap	1		
19	910800100088	1	O-Ring	1		
20	505798520008	2	Nut	4		
21	532098510000	2	Gear Pump	1		
22	910200200070	1	Screw	2		
23	505798520012	2	Pipe	2		
24	505798520010	2	Oil Tube	1		

Chapter 3: Truck Frame

01 Truck Frame, Foldable (509046021501)

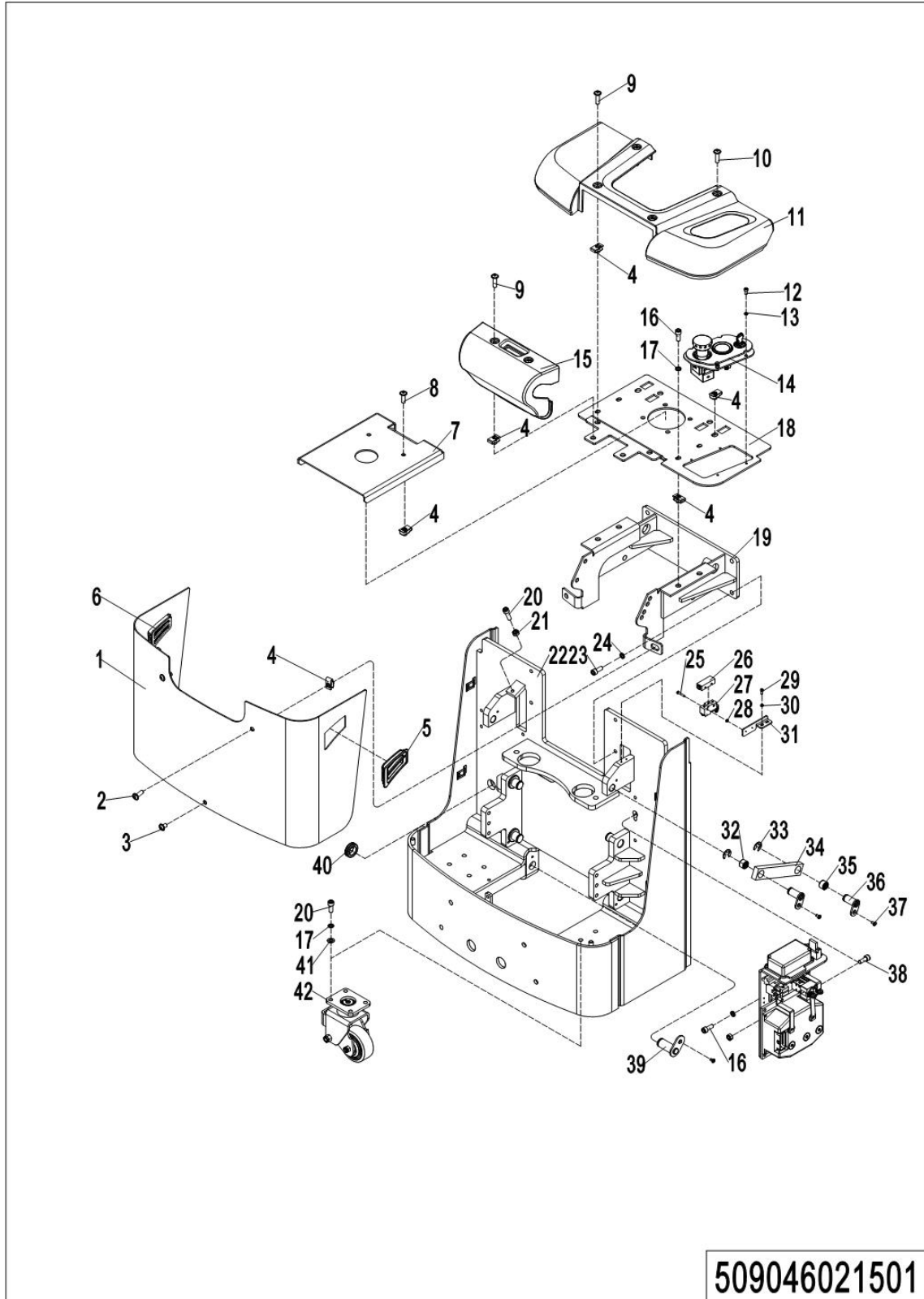

1=整包供货

2=限制供货

3=逐渐停止供货

4=不单件供货

5=见另外表单

01 Truck Frame, Foldable (509046021501)

No.	Item Code	Mark	Item Description	Qty.	Substitute	Note
1	505921510005		Apron	1		
2	941100100004		Screw	2		
3	941100100005		Screw	1		
4	940400400003		Cage Nut	14		
5	505621510004		Vent Kit	1		
6	505621510003		Vent Kit	1		
7	509021510006		Cover	1		
8	941100100006		Screw	2		
9	941100100003		Screw	4		
10	941100100002		Screw	2		
11	505921520032		Protective Cover	1		
12	910200200033		Screw	4		
13	910400500005		Spring Washer	4		
14	505610001000		Indicator Kit	1		
15	505621520025		Protective Cover	1		
16	910200200076		Screw	6		
17	910400500007		Spring Washer	14		
18	509021520039		Top Plate	1		
19	509021510002		Mounting Rack	1		
20	910200200078		Screw	9		
21	910300100007		Nut	2		
22	509021510000		Chassis	1		
23	910200200097		Screw	4		
24	910400500008		Spring Washer	4		
25	910200500027		Screw	2		
26	920200300008		Protective Cover	1		
27	920200300003		Microswitch	1		
28	910300100003		Nut	2		
29	910200200013		Screw	2		
30	910400500003		Spring Washer	2		

1=整包供货

2=限制供货

3=逐渐停止供货

4=不单件供货

5=见另外表单

01 Truck Frame, Foldable (509046021501) Continuation

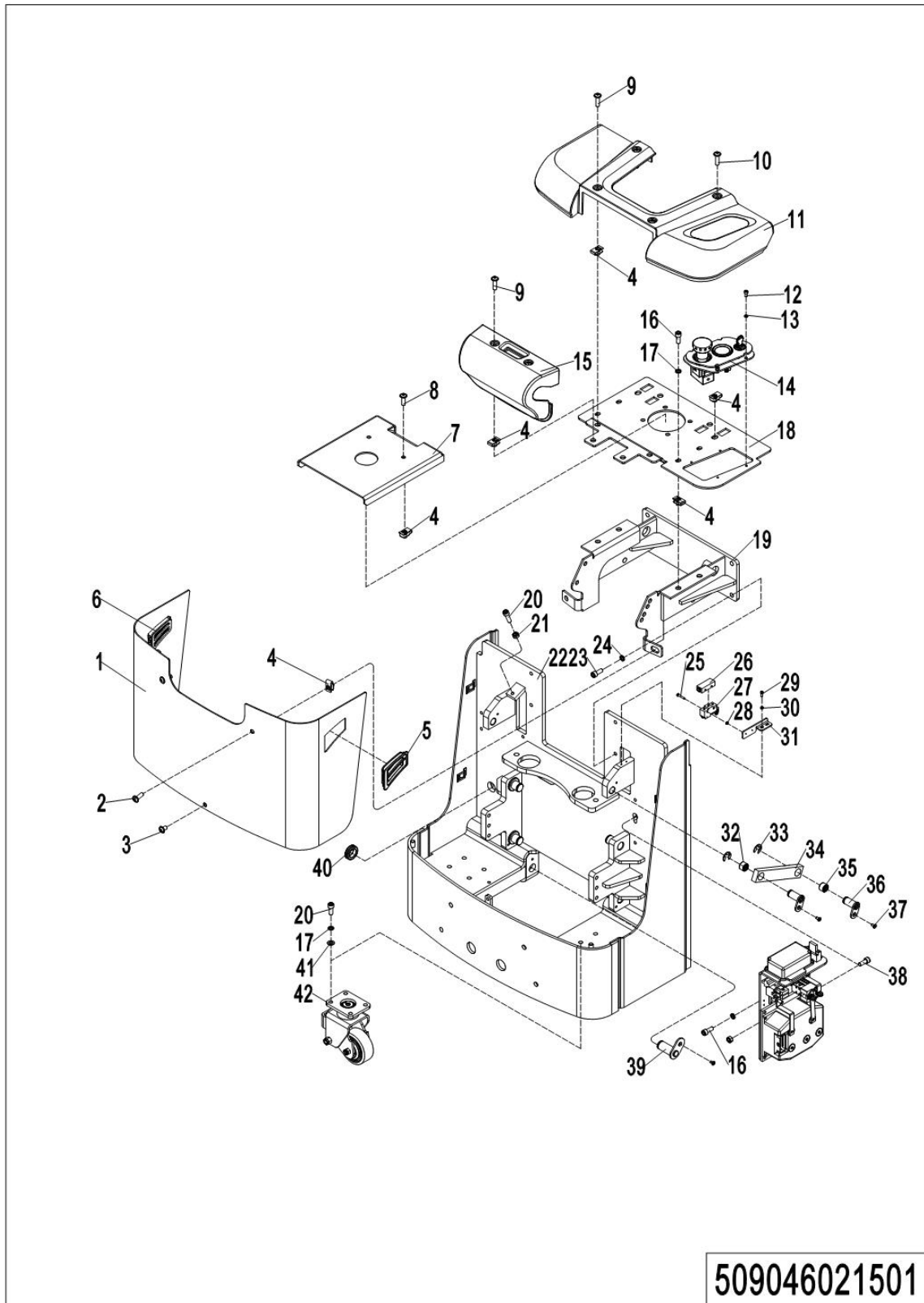

1=整包供货

2=限制供货

3=逐渐停止供货

4=不单件供货

5=见另外表单

01 Truck Frame, Foldable (509046021501) Continuation

No.	Item Code	Mark	Item Description	Qty.	Substitute	Note
31	509021520048		Mounting Plate	1		
32	940500200007		Bushing	2		
33	910401700005		Circlip	4		
34	509021520040		Rod	2		
35	940500100017		Bushing	2		
36	505921510003		Pin	4		
37	910200400016		Screw	4		
38	910200200077		Screw	1		
39	505921510002		Pin	2		
40	505621520036		Jacket	1		
41	910400100007		Flat Washer	8		
42	509016510000		Caster Assembly	2		

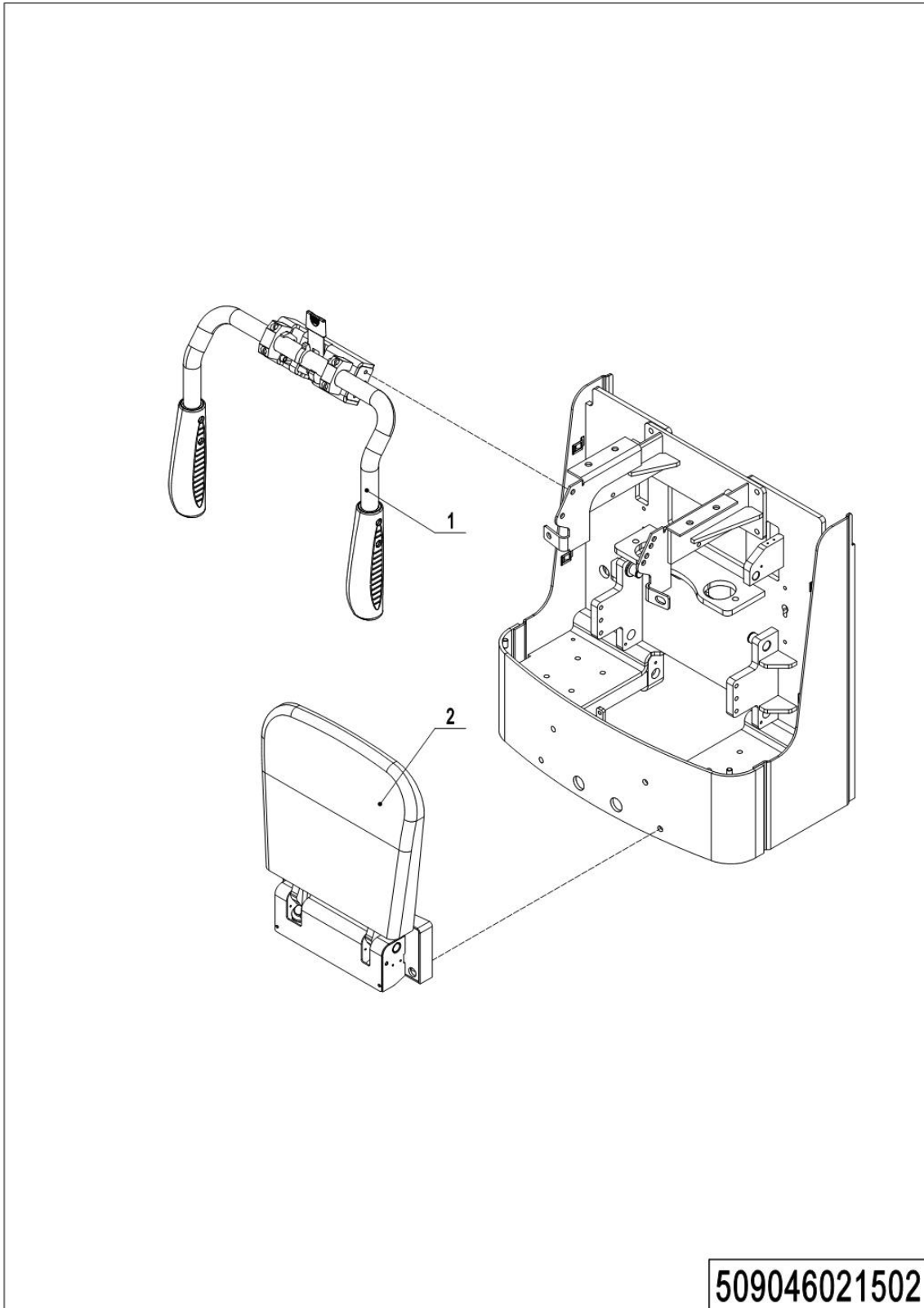
02 Truck Frame, Foldable (509046021502)

02 Truck Frame, Foldable (509046021502)

No.	Item Code	Mark	Item Description	Qty.	Substitute	Note
1	505698510012	5	Protective Arm	1		See 505646017501
2	505698510013	5	Footboard Kit	1		See 505646018001

03 Truck Frame, Fixed (509046021503)

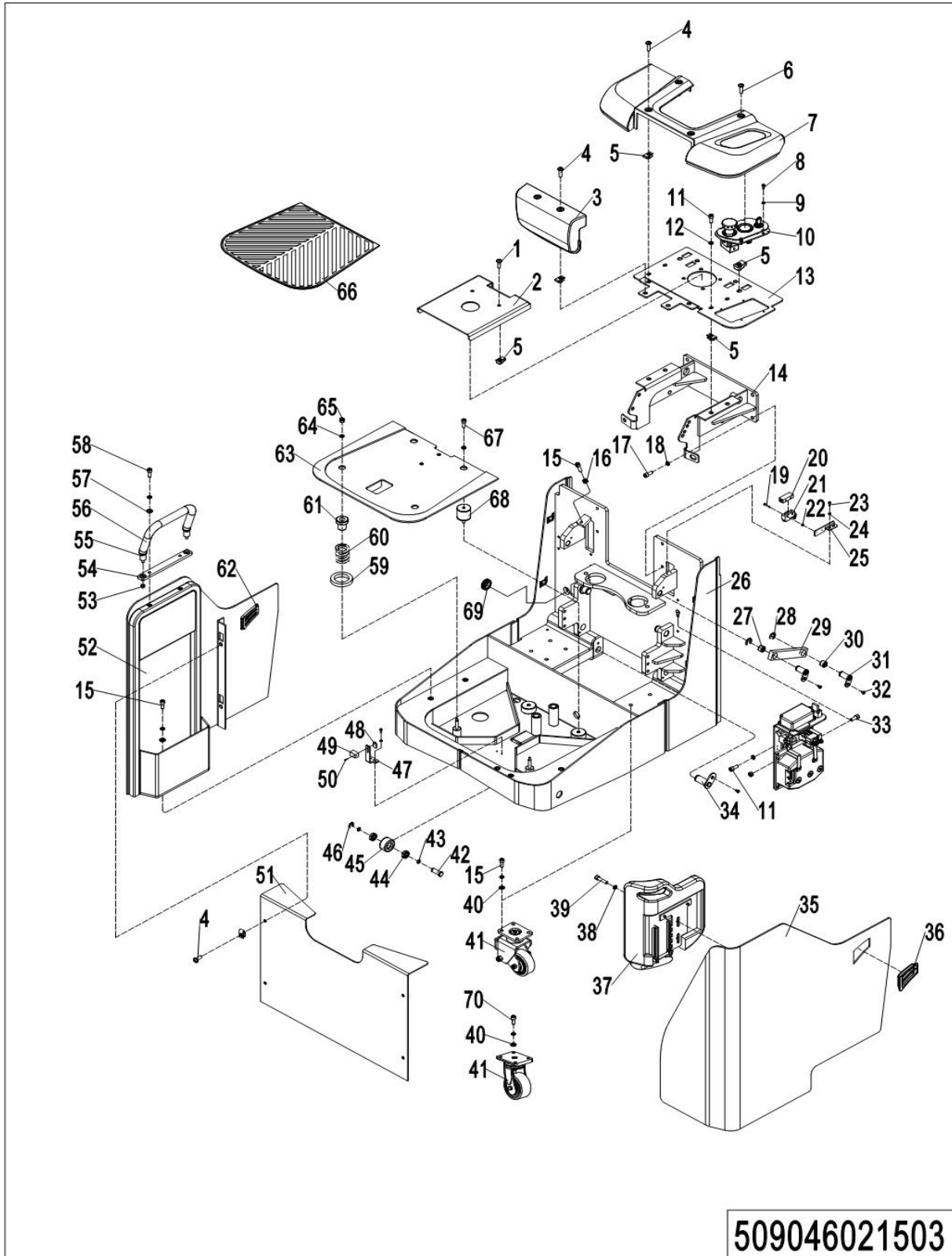

1=整包供货

2=限制供货

3=逐渐停止供货

4=不单件供货

5=见另外表单

03 Truck Frame, Fixed (509046021503)

No.	Item Code	Mark	Item Description	Qty.	Substitute	Note
1	941100100006		Screw	2		
2	509021510006		Cover	1		
3	505621520043		Protective Cover	1		
4	941100100003		Screw	4		
5	940400400003		Cage Nut	16		
6	941100100002		Screw	2		
7	505921520032		Protective Cover	1		
8	910200200033		Screw	4		
9	910400500005		Spring Washer	4		
10	505610001000		Indicator Kit	1		
11	910200200076		Screw	6		
12	910400500007		Spring Washer	22		
13	509021520039		Top Plate	1		
14	509021510002		Mounting Rack	1		
15	910200200078		Screw	15		
16	910300100007		Nut	2		
17	910200200097		Screw	4		
18	910400500008		Spring Washer	4		
19	910200500027		Screw	2		
20	920200300008		Protective Cover	1		
21	920200300003		Microswitch	1		
22	910300100003		Nut	2		
23	910200200013		Screw	4		
24	910400500003		Spring Washer	4		
25	509021520048		Mounting Plate	1		
26	509021510000		Chassis	1		
27	940500200007		Bushing	2		
28	910401700005		Circlip	4		
29	509021520040		Rod	2		
30	940500100017		Bushing	2		

1=整包供货

2=限制供货

3=逐渐停止供货

4=不单件供货

5=见另外表单

03 Truck Frame, Fixed (509046021503) Continuation

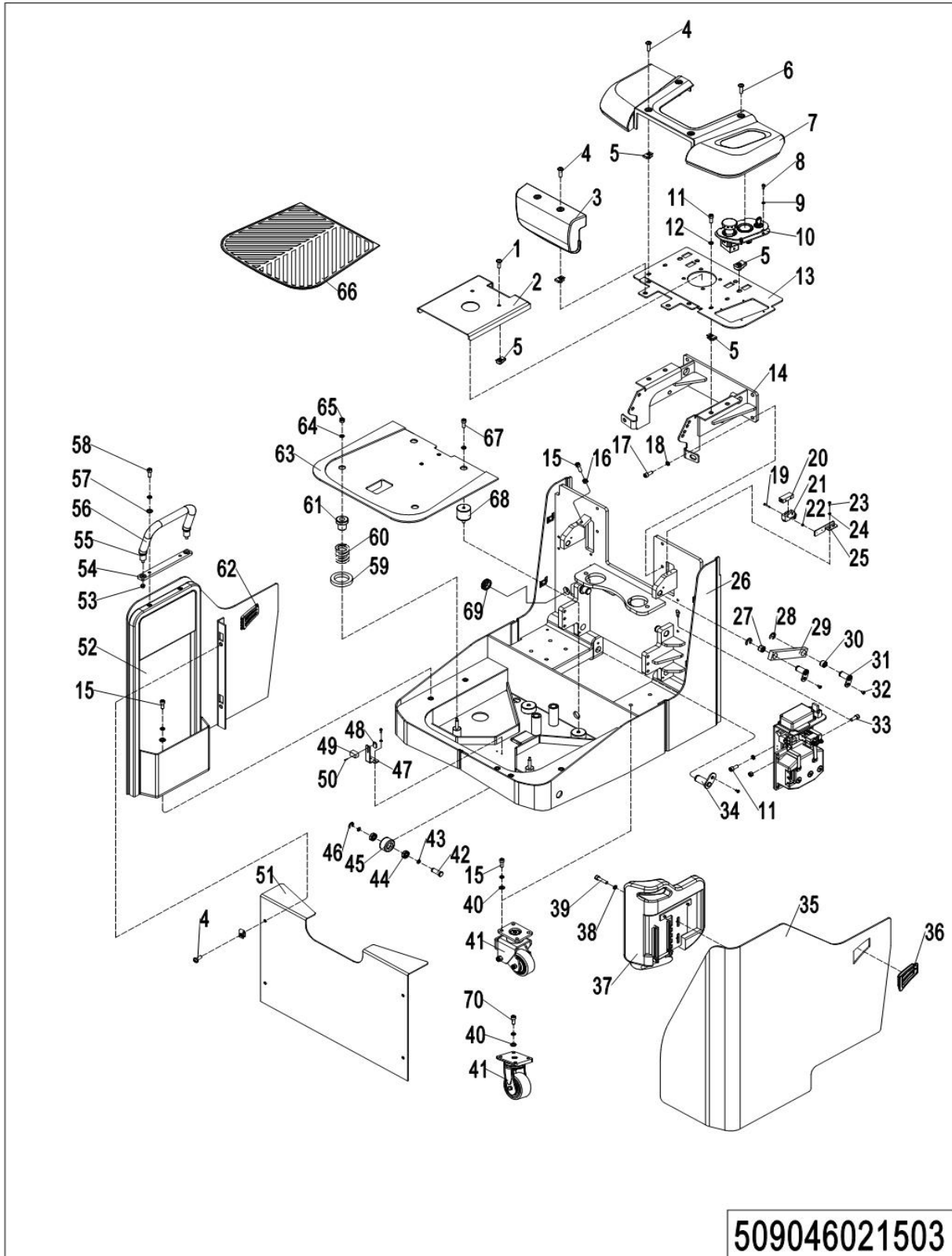

1=整包供货

2=限制供货

3=逐渐停止供货

4=不单件供货

5=见另外表单

03 Truck Frame, Fixed (509046021503) Continuation

No.	Item Code	Mark	Item Description	Qty.	Substitute	Note
31	505921510003		Pin	4		
32	910200400016		Screw	4		
33	910200200077		Screw	1		
34	505921510002		Pin	2		
35	509021510005		Protection Plate	1		
36	505621510004		Vent Kit	1		
37	218021510004		Backrest	1		
38	910400500006		Spring Washer	4		
39	910200200055		Screw	2		
40	910400100007		Flat Washer	14		
41	509016510000		Caster Assembly	2		
41	509516510001		Caster Assembly	2		See 509046016503
42	505921520077		Pin	1		
43	910400100011		Flat Washer	2		
44	910700200018		Bearing	2		
45	505921520079		Wheel	1		
46	910401300008		Circlip	1		
47	509021520046		Mounting Plate	1		
48	509021520054		Mounting Plate	1		
49	505633510002		Proximity Switch	1		
50	910200500016		Screw	2		
51	505921520070		Apron	1		
52	509021510004		Protection Plate	1		
53	910300500004		Nut	2		
54	509021520056		Baseboard	1		
55	509021510007		Handrail	1		
56	509021520060		Jacket	1		
57	910400100006		Flat Washer	2		
58	910200200058		Screw	2		
59	509021520047		Washer	2		

1=整包供货

2=限制供货

3=逐渐停止供货

4=不单件供货

5=见另外表单

03 Truck Frame, Fixed (509046021503) Continuation

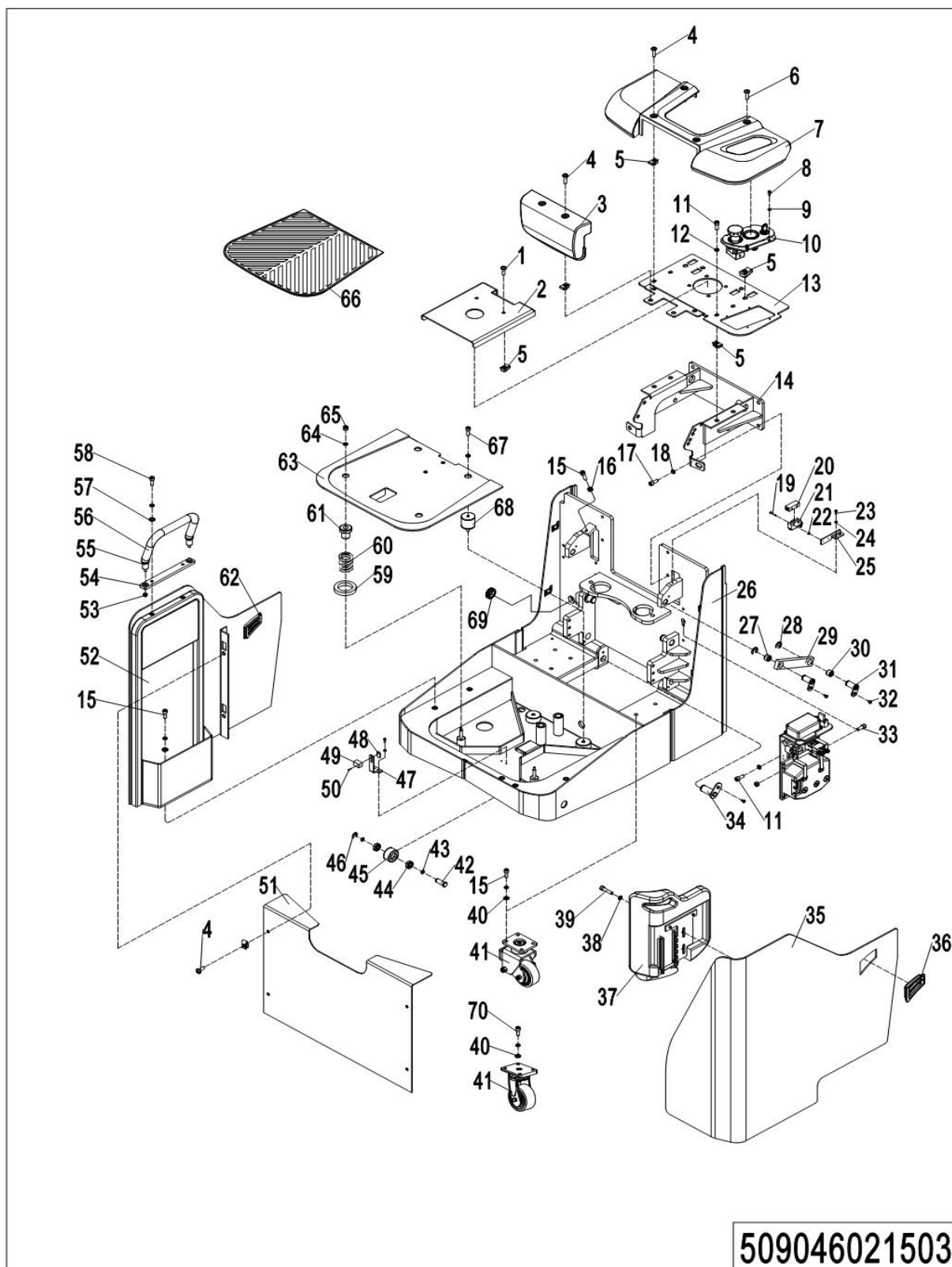

1=整包供货

2=限制供货

3=逐渐停止供货

4=不单件供货

5=见另外表单

03 Truck Frame, Fixed (509046021503) Continuation

No.	Item Code	Mark	Item Description	Qty.	Substitute	Note
60	940400500008		Spring	2		
61	565921520062		Crash Pad	2		
62	505621510003		Vent Kit	1		
63	50902151000		Platform	1		
64	910400200002		Flat Washer	2		
65	910300500003		Nut	2		
66	505618020018		Rubber Mat	1		
67	910200200007		Screw	2		
68	509021510003		Platform	1		
69	505621520036		Jacket	1		
70	910200200079		Screw	8		

Chapter 4:Chassis

01 Chassis (509046038501)

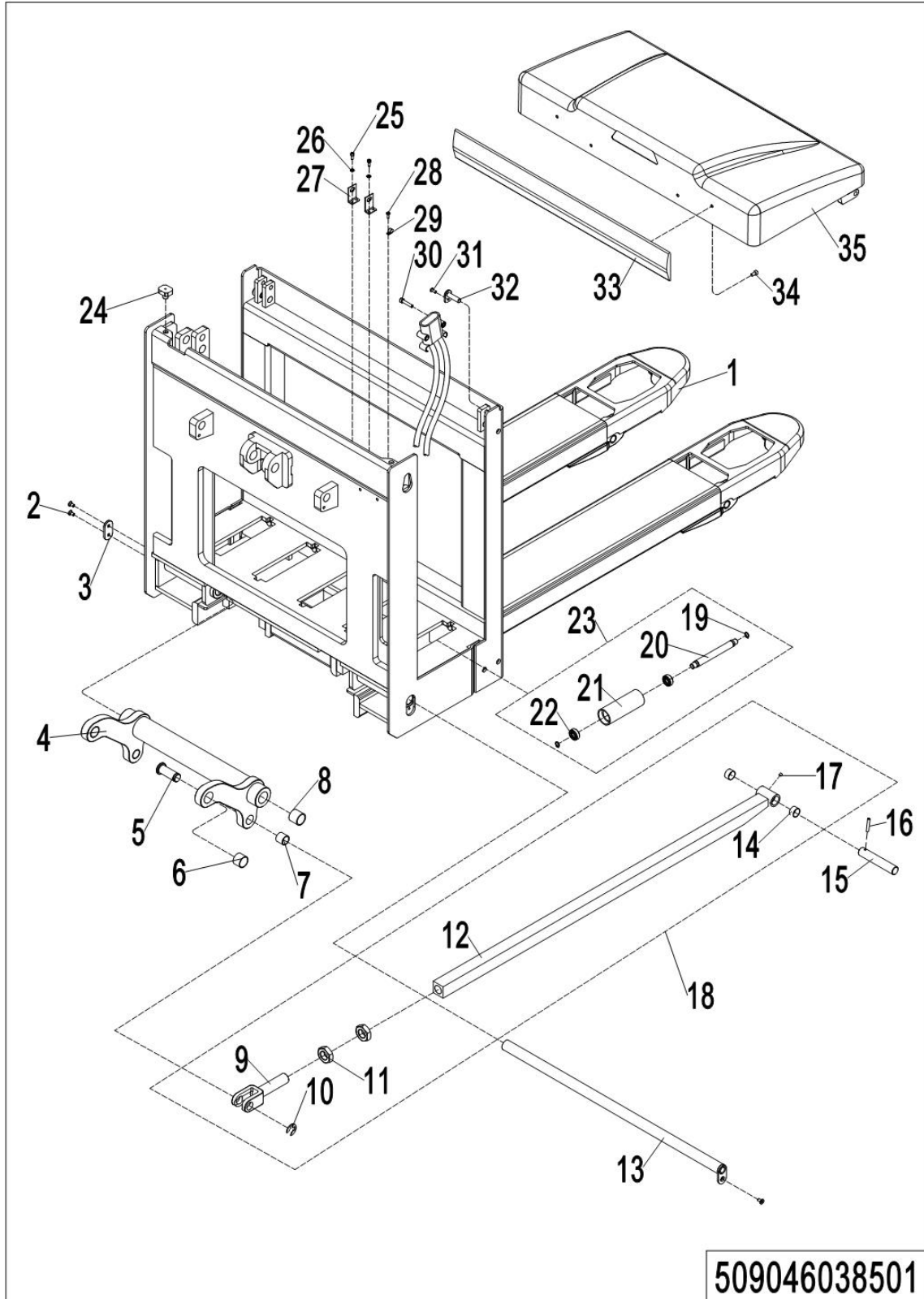

1=整包供货

2=限制供货

3=逐渐停止供货

4=不单件供货

5=见另外表单

01 Chassis (509046038501)

No.	Item Code	Mark	Item Description	Qty.	Substitute	Note
1	509038510000		Chassis(EU540x1150)	1		sideways Exchange
1	509038510001		Chassis(EU685x1220)	1		sideways Exchange
2	910200400016		Screw	3		
3	505638520031		Fixing Plate	1		
4	505638510001		Rise Arm	1		
4	505638510007		Rise Arm	1		
5	505638520034		Pin	2		
6	940500100027		Bushing	2		
7	940500100019		Bushing	2		
8	940500100097		Bushing	2		
9	505638520035		Push Rod Fork	2		
10	910401700005		Circlip	2		
11	910300400010		Nut	4		
12	509038510002		Push Rod (1150, EU)	2		sideways Exchange
12	509038510003		Push Rod (1220, EU)	2		sideways Exchange
13	509038510004		Pin	1		
14	940500100012		Bushing	4		
15	505638520037		Axle	2		
16	910600500004		Spring Pin	2		
17	911200100001		Oil Cup	2		
18	509098510000		Push Rod Kit (1150)	2		
18	509098510001		Push Rod Kit (1220)	2		
19	910401300006		Circlip	10		
20	505638520119		Axle	5		
21	505638520120		Roller	5		
22	910700200017		Bearing	10		
23	505638510028		Roller	5		
24	505938520016		Crash Pad	2		
25	910200200013		Screw	4		
26	910400500003		Spring Washer	4		

1=整包供货

2=限制供货

3=逐渐停止供货

4=不单件供货

5=见另外表单

01 Chassis (509046038501) Continuation

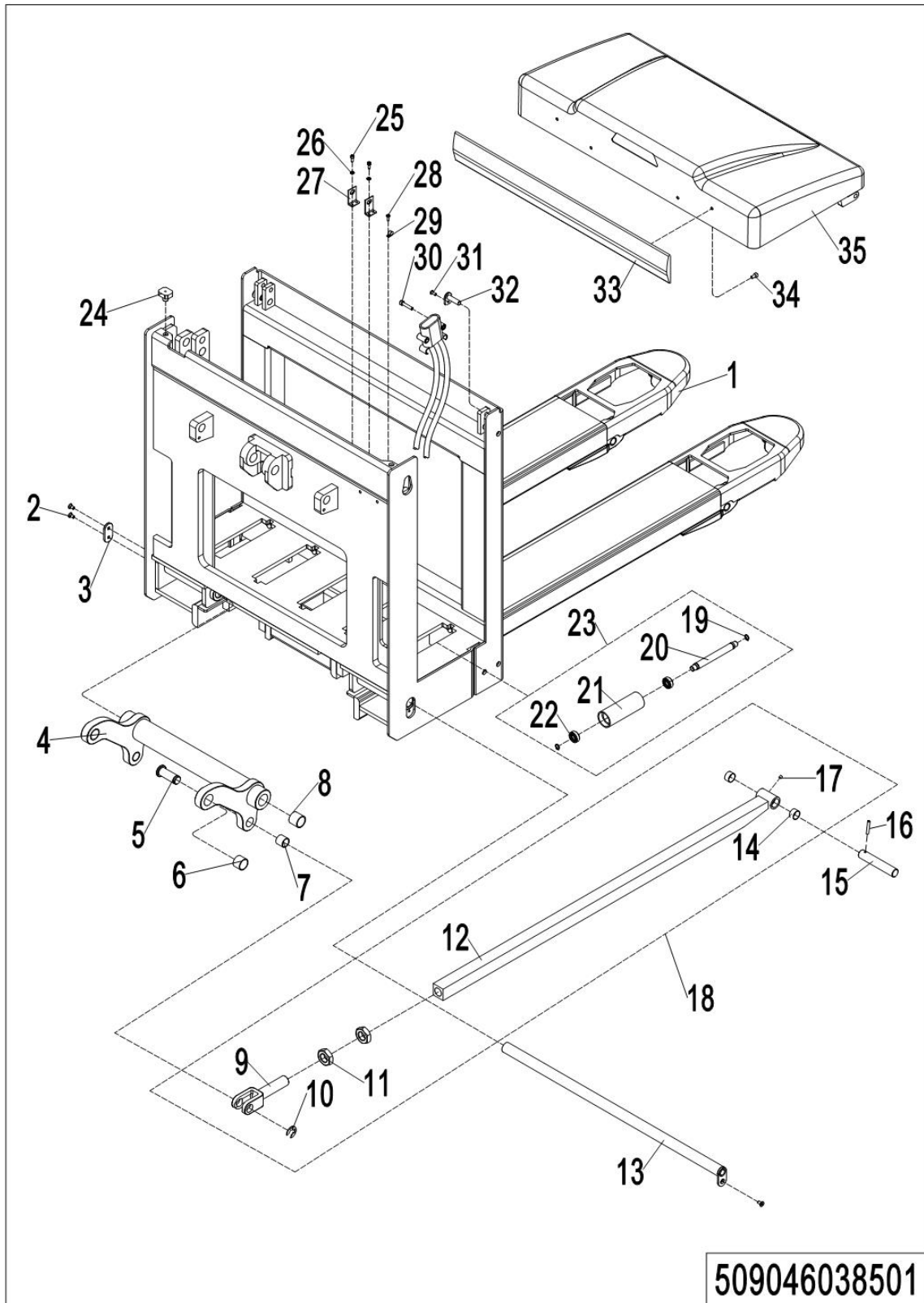

509046038501

1=整包供货

2=限制供货

3=逐渐停止供货

4=不单件供货

5=见另外表单

01 Chassis (509046038501) Continuation

No.	Item Code	Mark	Item Description	Qty.	Substitute	Note
27	921300300003		Holder	2		
28	910200500034		Screw	3		
29	921300200002		Cable Clamp	1		
30	910200200039		Screw	2		
31	910200300012		Screw	2		
32	509038510005		Pin	2		
33	505921020008		Protective Cover	1		
34	910200200032		Screw	4		
35	509021010000		Cell Cover	1		

Chapter 5: Steering System, Braking System, Wheels

01 Tiller Unit (505646011001)

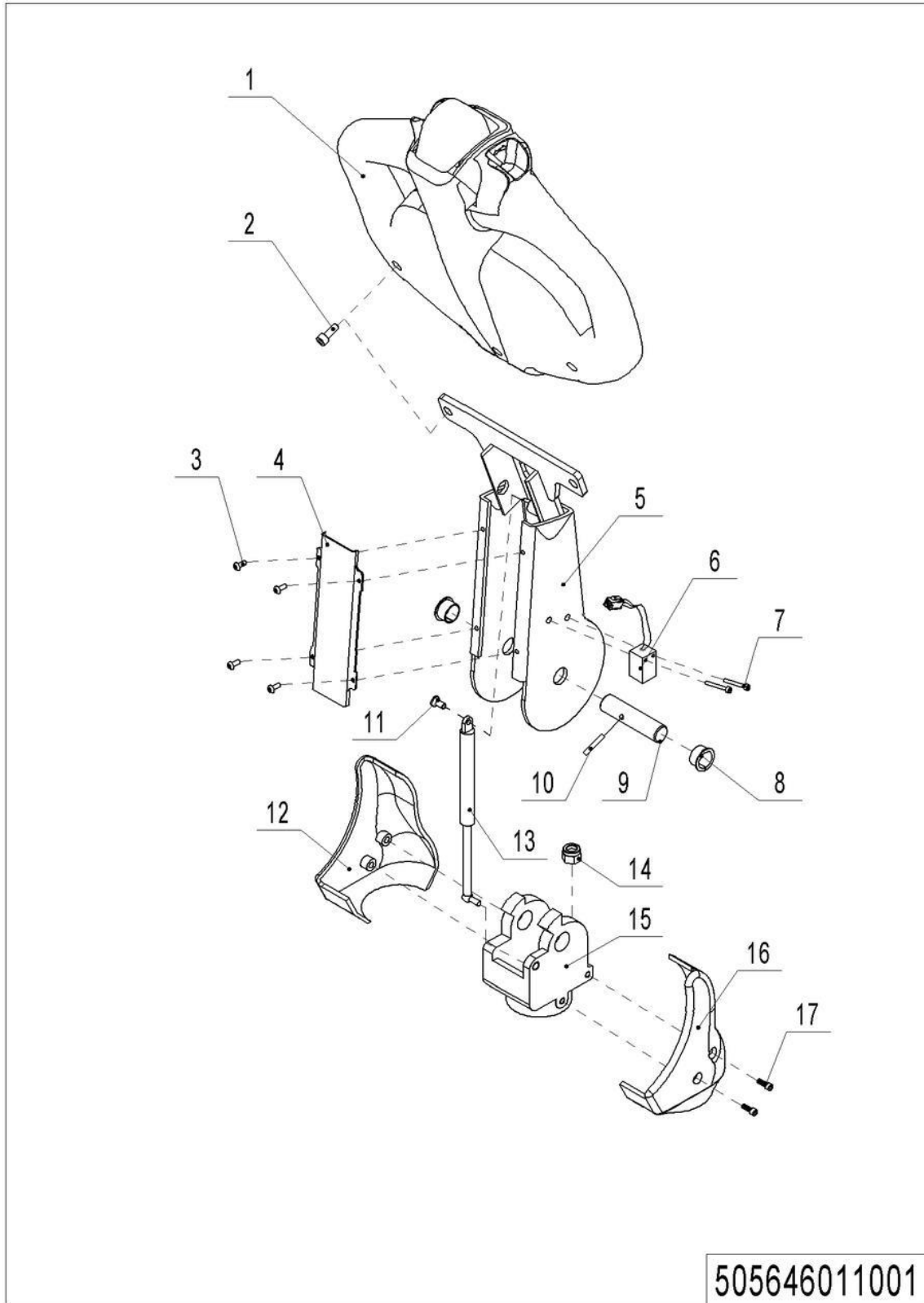

1=整包供货

2=限制供货

3=逐渐停止供货

4=不单件供货

5=见另外表单

01 Tiller Unit (505646011001)

No.	Item Code	Mark	Item Description	Qty.	Substitute	Note
1	922100100001		Tiller	1		
1	922100100012		Tiller	1		
2	910200200058	1	Screw	2		
3	910200300005	1	Screw	4		
4	505611020013		Close Plate	1		
5	505611010001		Tiller	1		
5	505611010000		Tiller	1		
6	505633510000	2	Proximity Switch	1		
7	910200500015	1	Screw	2		
8	940500200002		Bushing	2		
9	505611020008		Axle	1		
10	910600400013	1	Spring Pin	1		
11	910200200057	1	Screw	1		
12	505611020010		Protective Cover	1		
13	940400100003		Air Spring	1		
14	910300500005	1	Nut	2		
15	505611020009		Bracket	1		
16	505611020011		Protective Cover	1		
17	910200300016	1	Screw	4		

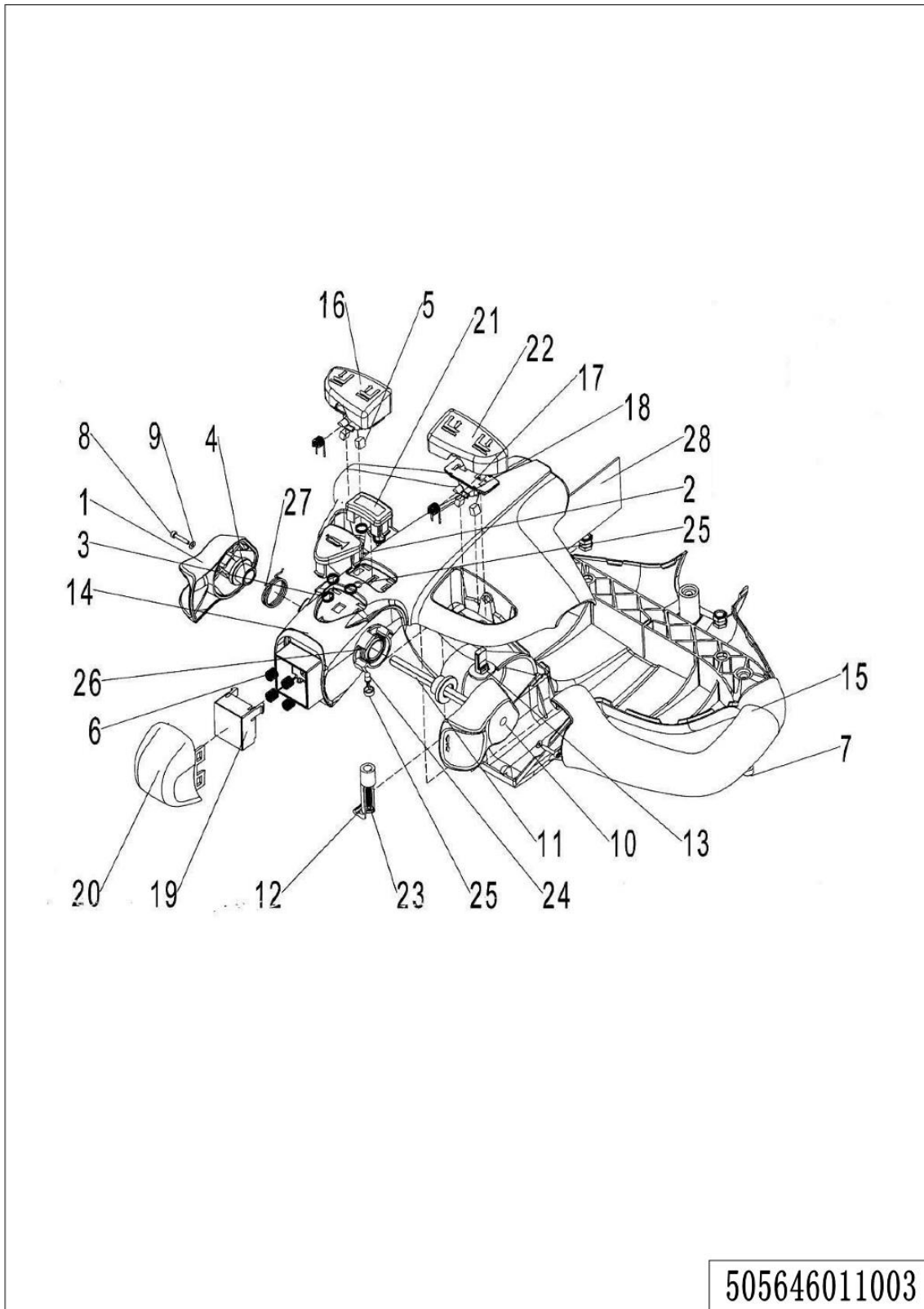
02 Control Handle (505646011003)

02 Control Handle (505646011003)

No.	Item Code	Mark	Item Description	Qty.	Substitute	Note
1	505698520001		Traction lever	1		
2	505698520002		Horn Button	1		
3	505698520003		Spring	5		
4	505698520004		Sleeve	2		
5	505698520005		Magnet	4		
6	505698520006		Spring	4		
7	505698520007		Screw	3		
8	505698520008		Screw	2		
9	505698520009		Washer	2		
10	505698520010		Traction lever	1		
11	505698520011		Axle-Traction lever	1		
12	505698520012		Clamp	1		
13	505698520013		Sensor	2		
14	505698520014		Handle Cap	1		
15	505698520015		Handle Cap	1		
16	505698520016		Button cap	1		
17	505698520017		Fixing Base	2		
18	505698520018		Torsional Spring	2		
19	505698520019		Pedestal	1		
20	505698520020		Button Cap-	1		
21	505698520021		Button Cap	1		
22	505698520022		Button Cap	1		
23	505698520023		Screw	1		
24	505698520024		Light	1		
25	505698520025		Lamp Holder	1		
26	505698520026		Torsional Spring	1		
27	505698520027		Torsional Spring	1		
28	505698520028		circuit Board	1		

03 Load Wheel (Tandem) (505646017001)

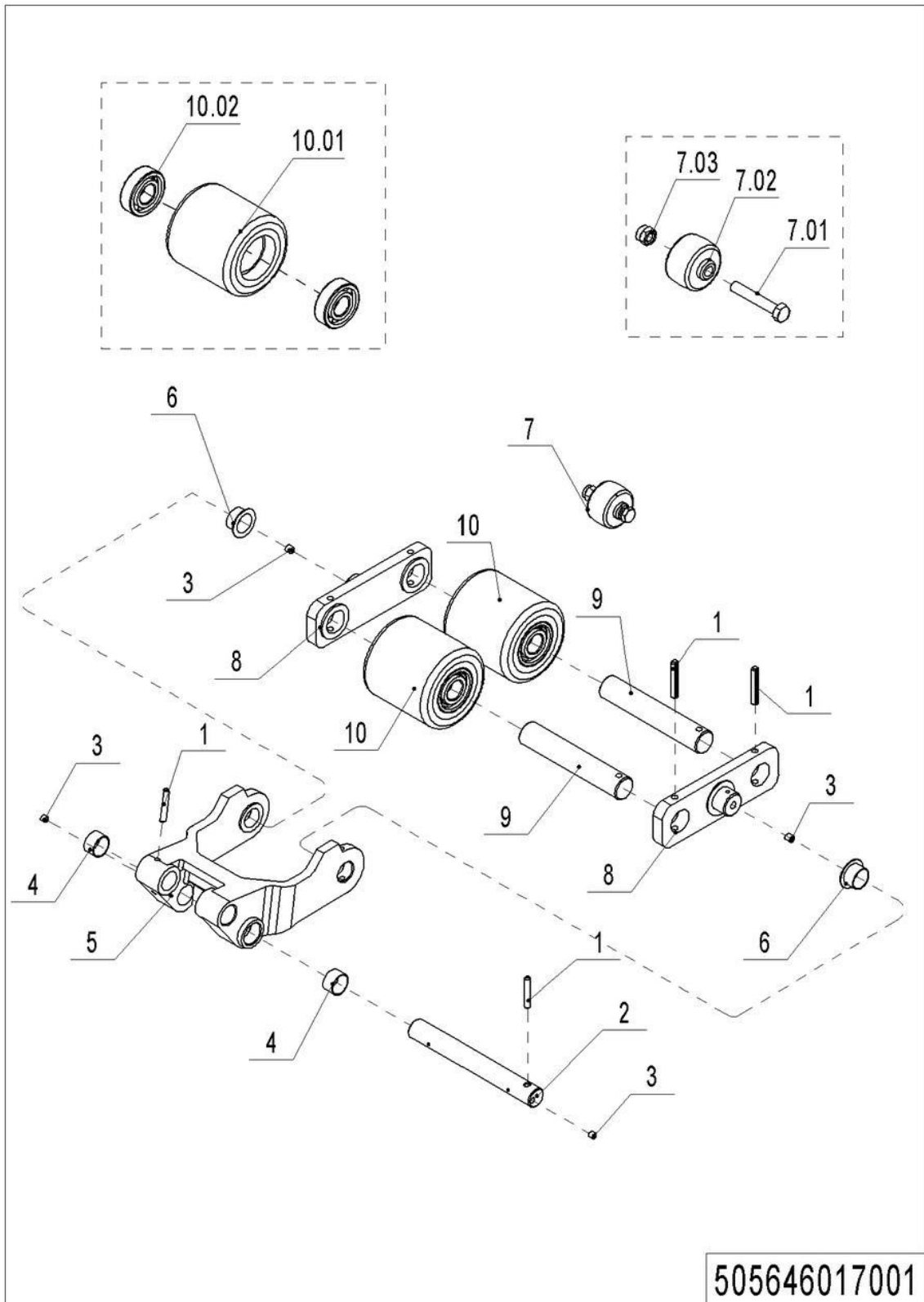

1=整包供货

2=限制供货

3=逐渐停止供货

4=不单件供货

5=见另外表单

03 Load Wheel (Tandem) (505646017001)

No.	Item Code	Mark	Item Description	Qty.	Substitute	Note
1	910600400027	1	Spring Pin	8		
2	505638520038		Pin	2		
3	911200100001		Oil Cup	2		
4	940500100012		Bushing	4		
5	505638520036		Riser	2		
6	940500200003		Bushing	2		
7	502398510003		Pulley components	2		
7.01	910300500005	1	Nut	2		
7.02	505638520039		Running Pulley	2		
7.03	910100100035	1	Bolt	2		
8	505617020001		Plate	4		
9	505617020000		Axle	4		
10	505698510003		Wheel	4		
10.01	940300300010		WheelΦ84x84	4		
10.02	910700200019		Bearing	8		

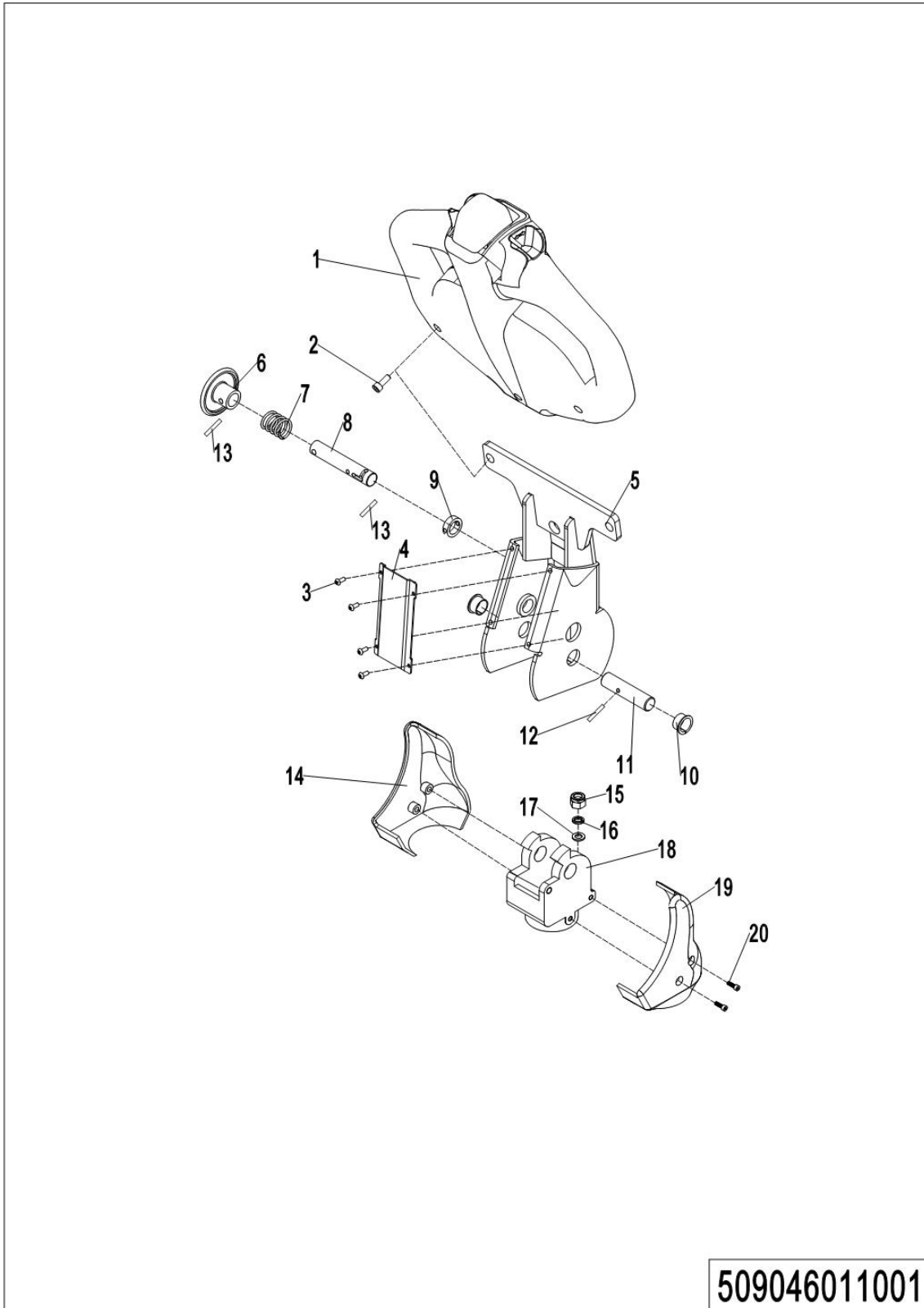
04 Control Handle, Fixed (509046011001)

1=整包供货

2=限制供货

3=逐渐停止供货

4=不单件供货

5=见另外表单

04 Control Handle, Fixed (509046011001)

No.	Item Code	Mark	Item Description	Qty.	Substitute	Note
1	922100100001		Tiller	1		
2	910200200058		Screw	2		
3	910200300005		Screw	4		
4	565911020000		Close Plate	1		
5	565911010000		Tiller	1		
6	565911020001		Handwheel	1		
7	940400500002		Spring	1		
8	565911020004		Locating Pin	1		
9	565911020003		Spacer Bush	1		
10	940500200002		Bushing	2		
11	565911020005		Axle	1		
12	910600400015		Spring Pin	1		
13	910600400022		Spring Pin	2		
14	505611020010		Protective Cover	1		
15	910300100007		Nut	2		
16	910400500007		Spring Washer	2		
17	910400100007		Flat Washer	2		
18	565911020002		Bracket	1		
19	505611020011		Protective Cover	1		
20	910200300016		Screw	4		

05 Caster 2.0t,2.5t,3.0t (509046016501)

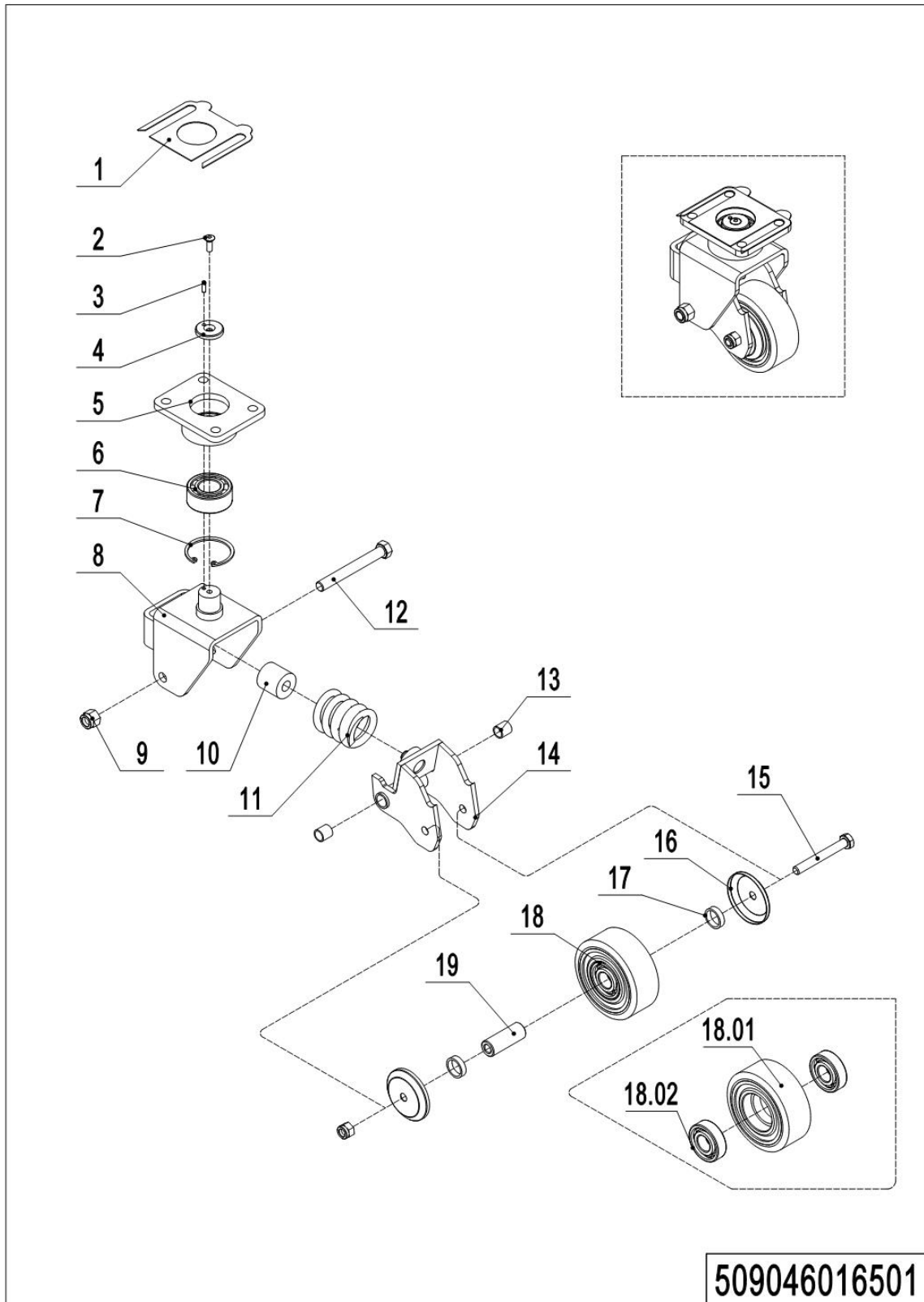

1=整包供货

2=限制供货

3=逐渐停止供货

4=不单件供货

5=见另外表单

05 Caster 2.0t,2.5t,3.0t (509046016501)

No.	Item Code	Mark	Item Description	Qty.	Substitute	Note
1	505616520014		Pad	2		
2	941100300001	1	Screw	2		
3	910600100004	1	Cylindrical Pin	2		
4	505616520007		Retaining Ring	2		
5	509016510003		Plate	2		
6	910700500002		Bearing	2		
7	910401400016		Circlip	2		
8	509016510001		Wheel Carrier	2		
9	910300500006	1	Nut	1		
10	505616520000		Spring	2		
11	940400500007		Spring	2		
12	910100100060	1	Bolt	2		
13	940500100002		Bushing	4		
14	509016510002		Whirling Arm	2		
15	910100100058	1	Bolt	2		
16	505916520010		Dust Cap	4		
17	505616520012		Check Ring	4		
18	532698510004		Wheel	2		
18.01	940300300019		WheelΦ124x60	2		
18.02	910700200019		Bearing	4		
19	505616520013		Bushing	2		

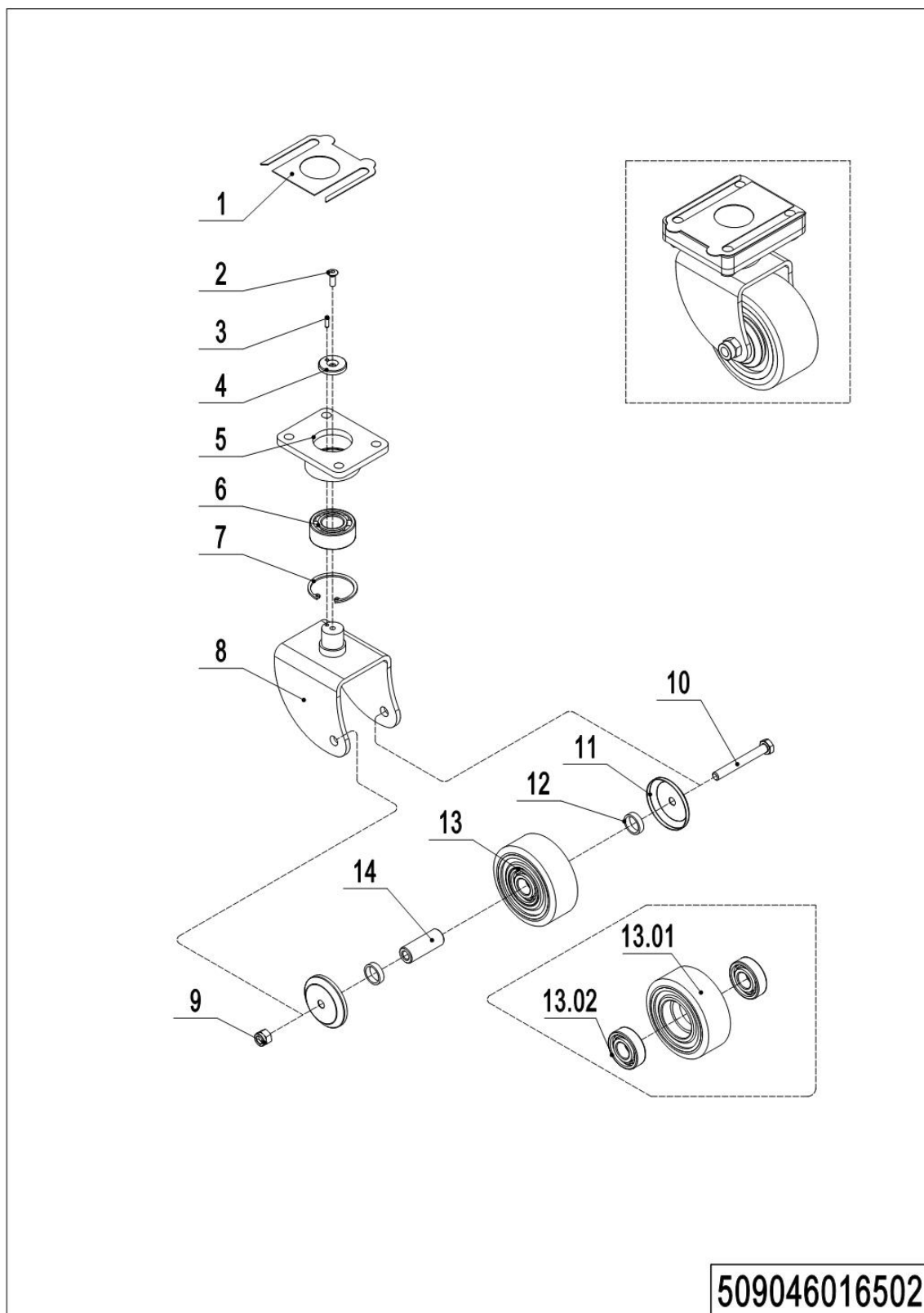
06 Caster (2.0t specific type) (509046016502)

06 Caster (2.0t specific type) (509046016502)

No.	Item Code	Mark	Item Description	Qty.	Substitute	Note
1	505616520014		Pad	2		
2	941100300001	1	Screw	2		
3	910600100004	1	Cylindrical Pin	2		
4	505616520007		Retaining Ring	2		
5	509016510003		Plate	2		
6	910700500002		Bearing	2		
7	910401400016		Circlip	2		
8	509516510005		Wheel Carrier	2		
9	910300500006	1	Nut	2		
10	910100100058	1	Bolt	2		
11	505916520010		Dust Cap	4		
12	505616520012		Check Ring	4		
13	532698510004		Wheel	2		
13.01	940300300019		WheelΦ124x60	2		
13.02	910700200019		Bearing	4		
14	505616520013		Bushing	2		

07 Caster (2.5t specific type) (509046016503)

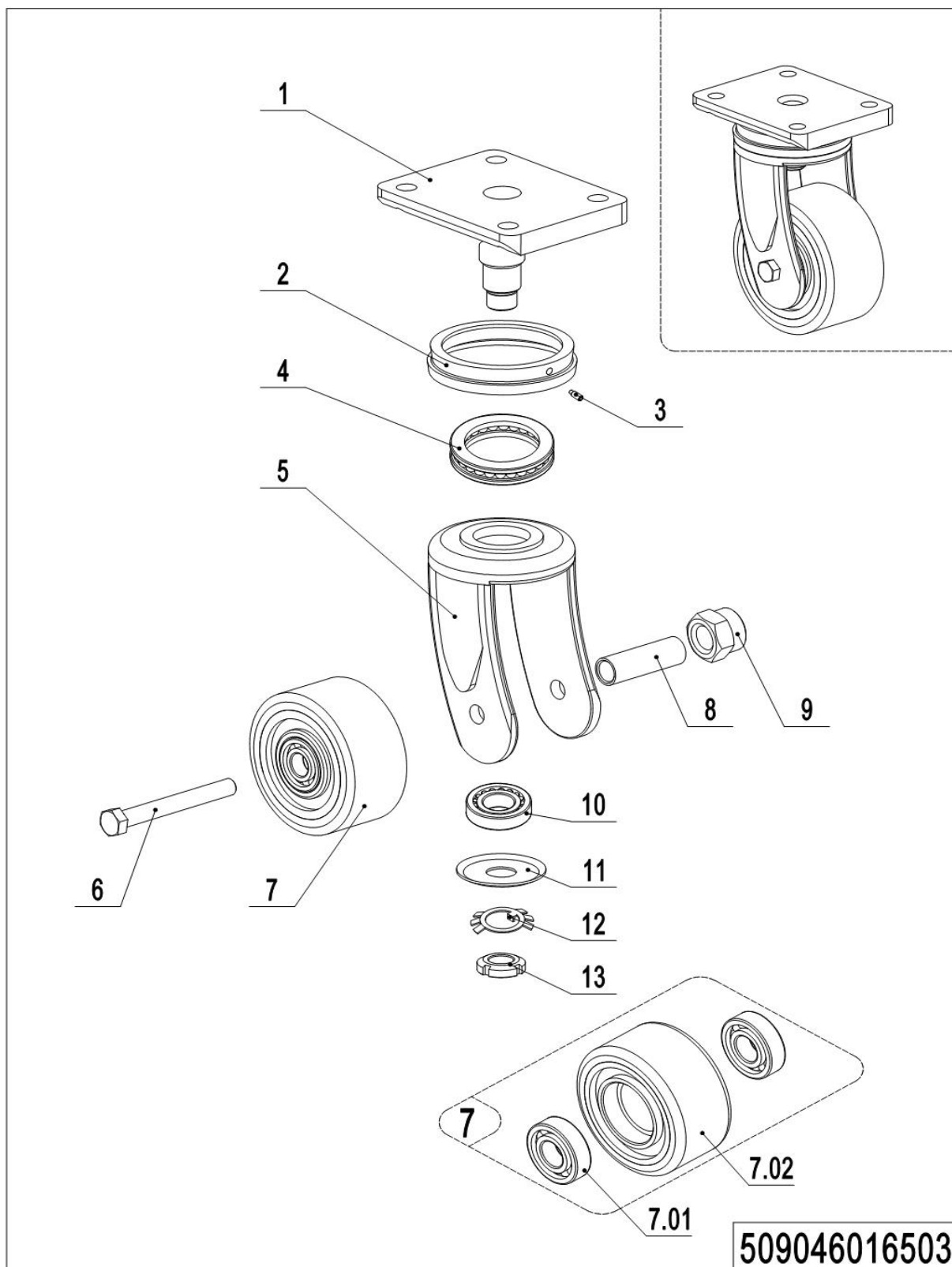

1=整包供货

2=限制供货

3=逐渐停止供货

4=不单件供货

5=见另外表单

07 Caster (2.5t specific type) (509046016503)

No.	Item Code	Mark	Item Description	Qty.	Substitute	Note
1	509516510000		Flange	2		
2	533216520002	1	Dust Cap	2		
3	401716520009	1	Oil Cup	2		
4	910700700002		Bearing	2		
5	509516520001		Caster Frame	2		
6	910100100058		Bolt	2		
7	532698510004		Wheel	2		
7.01	940300300019		Wheel	2		
7.02	910700200019		Bearing	4		
8	509516520005		Bushing	2		
9	910300500006		Nut	2		
10	910700600001		Bearing	2		
11	533216520004		Cover	2		
12	910400900002		Lock Washer	2		
13	910300800002		Nut	2		

08 Control Handle, detong (505646011002)

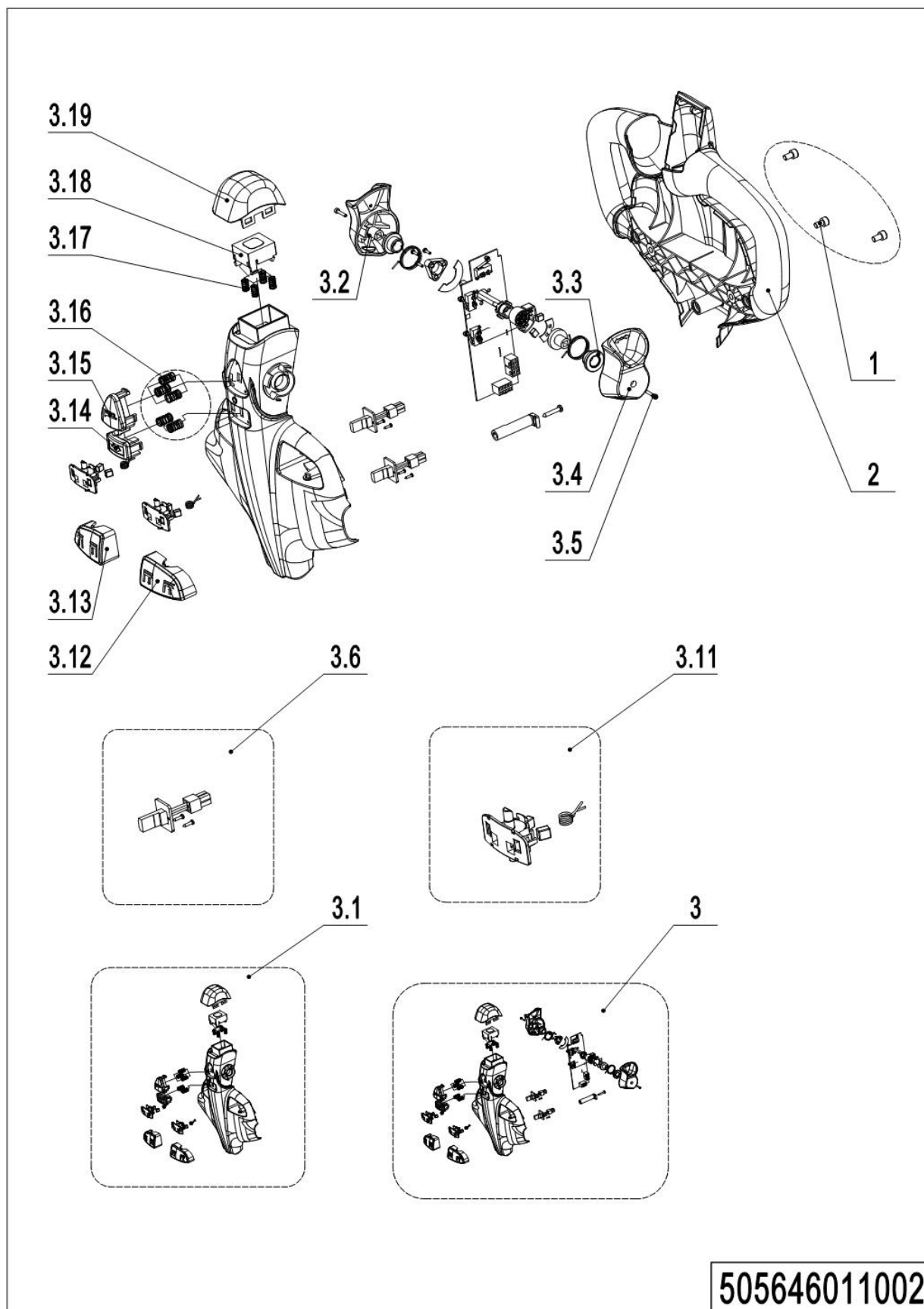

1=整包供货

2=限制供货

3=逐渐停止供货

4=不单件供货

5=见另外表单

08 Control Handle, detong (505646011002)

No.	Item Code	Mark	Item Description	Qty.	Substitute	Note
1	910200200032	1	Screw	3		M6×10
2	505698520124	2	Handle Cap	1		
3	505698510024	2	Handle Cap Kit	1		
3.1	505698510021	2	Handle Cap Kit	1		
3.11	505698510023	2	Sensor	1		
3.12	505698520113	2	Button	1		
3.13	505698520114	2	Button	1		
3.14	505698520115	2	Button	1		
3.15	505698520116	2	Button	1		
3.16	505698520117	2	Spring	5		
3.17	505698520118	2	Spring	4		
3.18	505698520119	2	Cover	1		
3.19	505698520120	2	Cover	1		
3.2	505698520121	2	Traction lever	1		
3.3	505698520122	2	Sleeve	2		
3.4	505698520123	2	Traction lever	1		
3.5	910200200004	1	Screw	2		M3×16
3.6	505698510022	2	Magnetic Steel Base Kit	1		

Chapter 6: Electrical Parts

01 Display Assembly (509046010001)

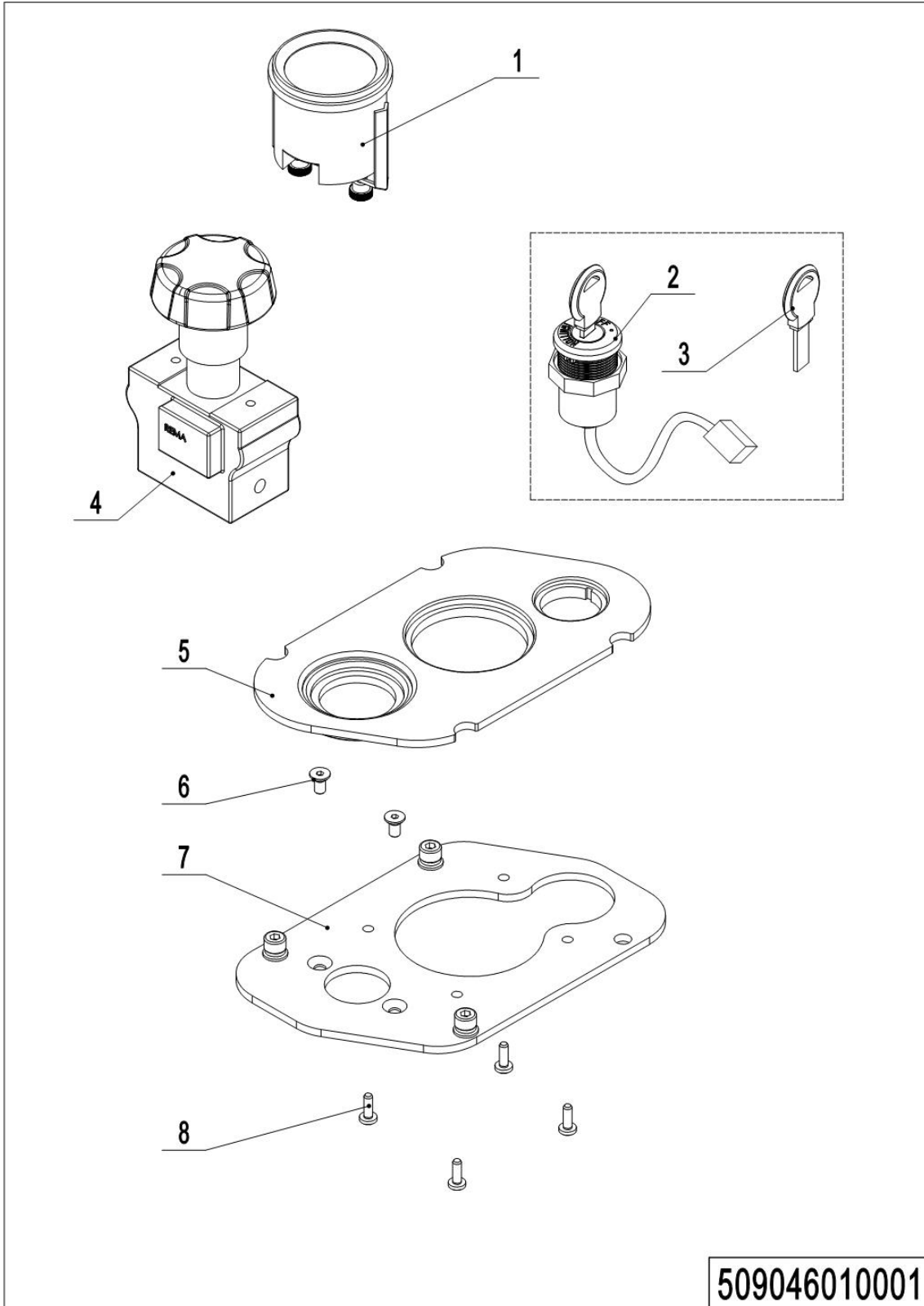

1=整包供货

2=限制供货

3=逐渐停止供货

4=不单件供货

5=见另外表单

01 Display Assembly (509046010001)

No.	Item Code	Mark	Item Description	Qty.	Substitute	Note
1	921100100044		Battery Indicator	1		
1	921100100086		Battery Indicator	1		Li
2	505602034001		Key Switch	1		
2	505634010001		Key Switch	1		Li
3	505698520031		Key	1		
3	920200200028		Key	1		Li
8	920200100001		Emergency Button	1		
9	505610020000		Panel	1		
10	910200400010	1	Screw	2		
11	505610020001		Fixing Plate	1		
12	910201300001	1	Screw	4		

02 Charger, Lead acid (509046036501)

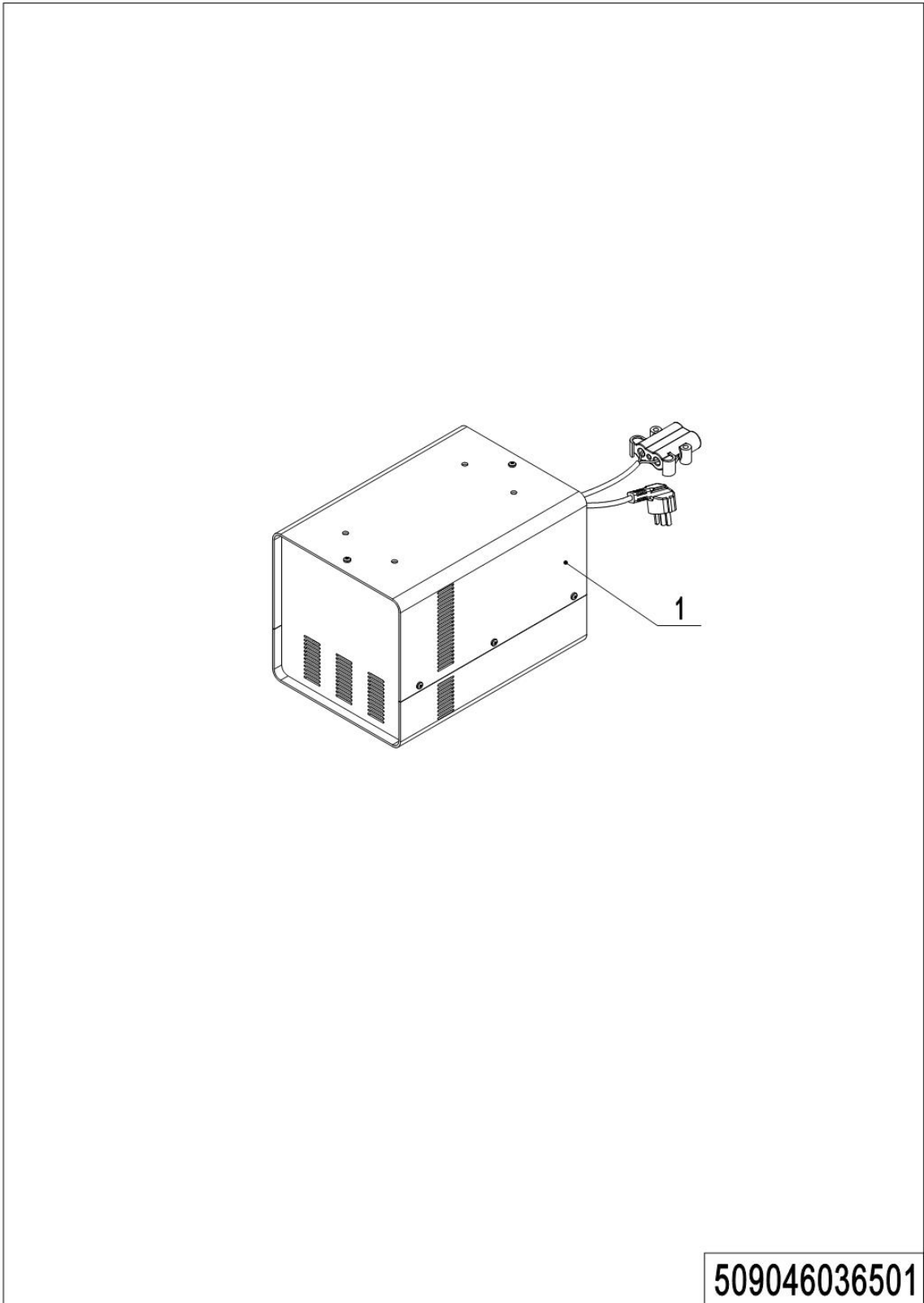

509046036501

02 Charger, Lead acid (509046036501)

No.	Item Code	Mark	Item Description	Qty.	Substitute	Note
1	921000200391		Charger24V20A(Aisa-CHN)	1		
1	921000200392		Charger24V20A(Aisa-ENG)	1		
1	921000200393		Charger24V20A(EU)	1		
1	921000200394		Charger24V20A(ENG)	1		
1	921000200395		Charger24V20A(AUS)	1		
1	921000200396		Charger24V20A(USA)	1		
1	921000200001	2	Charger24V30A(Aisa-CHN)	1		
1	921000200002	2	Charger24V30A(Aisa-ENG)	1		
1	921000200003	2	Charger24V30A(EU)	1		
1	921000200004	2	Charger24V30A(AUS)	1		
1	921000200005	2	Charger24V30A(ENG)	1		
1	921000200006	2	Charger24V30A(USA)	1		
1	921000200546		Charger 24V30A(LTA)			
1	921000200151	2	Charger24V30A(Aisa-CHN)	1		NOBLELIFT
1	921000200153	2	Charger24V30A(Aisa-ENG)	1		NOBLELIFT
1	921000200152	2	Charger24V30A(EU)	1		NOBLELIFT
1	921000200154	2	Charger24V30A(ENG)	1		NOBLELIFT
1	921000200183		Charger24V35A(Aisa-CHN)	1		
1	921000200184		Charger24V35A(Aisa-ENG)	1		
1	921000200185		Charger24V35A(EU)	1		
1	921000200186		Charger24V35A(ENG)	1		
1	921000200187		Charger24V35A(AUS)	1		
1	921000200188		Charger24V35A(USA)	1		
1	921000200155		Charger24V40A(Aisa-CHN)	1		NOBLELIFT
1	921000200156		Charger24V40A(Aisa-ENG)	1		NOBLELIFT

03 Charger, Lithium battery (509046036502)

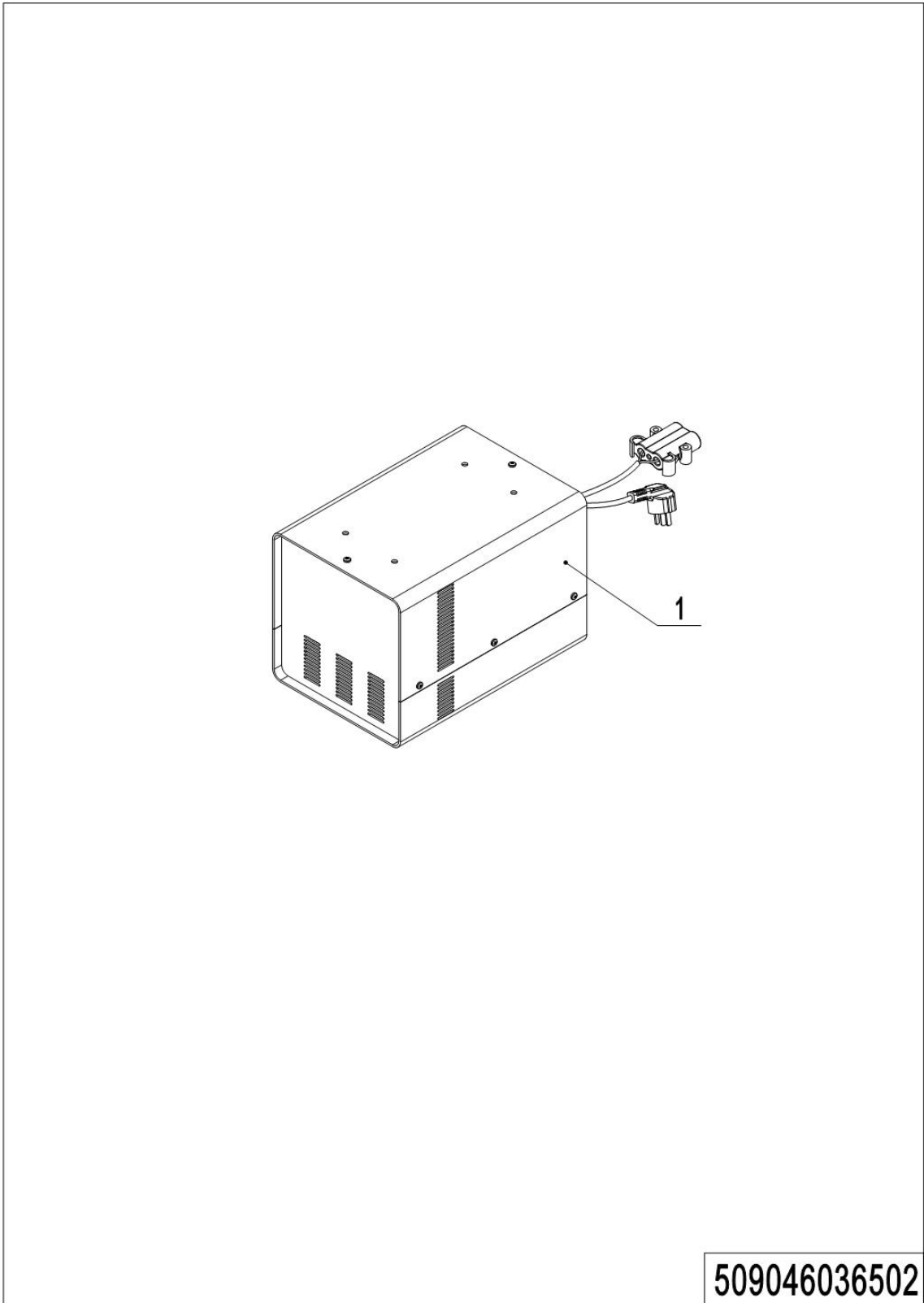

02 Charger, Lithium battery (509046036502)

No.	Item Code	Mark	Item Description	Qty.	Substitute	Note
1	921000200522		Charger 24V60A(Aisa-CHN)	1		
1	921000200523		Charger 24V60A (Aisa-ENG)	1		
1	921000200524		Charger 24V60A (EU)	1		
1	921000200525		Charger 24V60A (ENG)	1		
1	921000200526		Charger 24V60A (AUS)	1		
1	921000200527		Charger 24V60A (ISR)	1		
1	921000200528		Charger 24V60A (ARG)	2		
1	921000200529		Charger 24V60A (RSA)	1		
1	921000200530		Charger 24V60A (USA)	1		
1	921000200531		Charger 24V80A (Aisa-CHN)	1		
1	921000200532		Charger 24V80A (Aisa-ENG)	1		
1	921000200533		Charger 24V80A (EU)	1		
1	921000200534		Charger 24V80A (ENG)	1		
1	921000200535		Charger 24V80A (AUS)	1		
1	921000200536		Charger 24V80A (ISR)	1		
1	921000200537		Charger 24V80A (ARG)	1		
1	921000200538		Charger 24V80A (RSA)	1		
1	921000200539		Charger 24V80A (USA)	1		

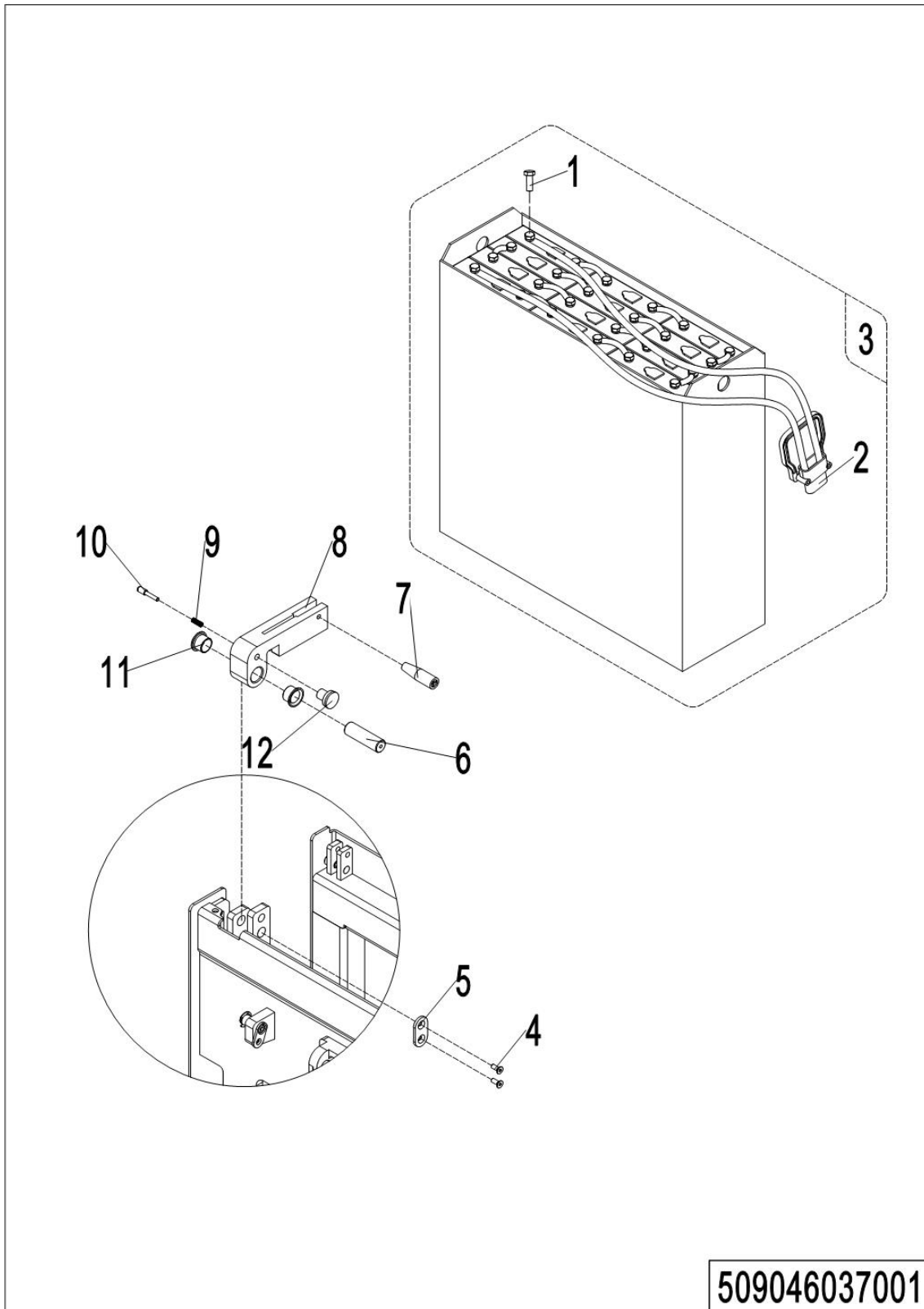
04 Lead acid (509046037001)

1=整包供货

2=限制供货

3=逐渐停止供货

4=不单件供货

5=见另外表单

04 Lead acid (509046037001)

No.	Item Code	Mark	Item Description	Qty.	Substitute	Note
1	505698520000		Bolt	24		
2	509098510003		Connector	1		
3	505637010006		Battery24V180Ah	1		
4	910200400016		Screw	2		
5	505638520031		Fixing Plate	1		
6	506938520000		Axle	1		
7	911000400001		Tiller	1		
8	506738520040		Stop Block	1		
9	940400500001		Spring	1		
10	505638520122		Screw	1		
11	940500200008		Bushing	2		
12	505638520123		Handle	1		

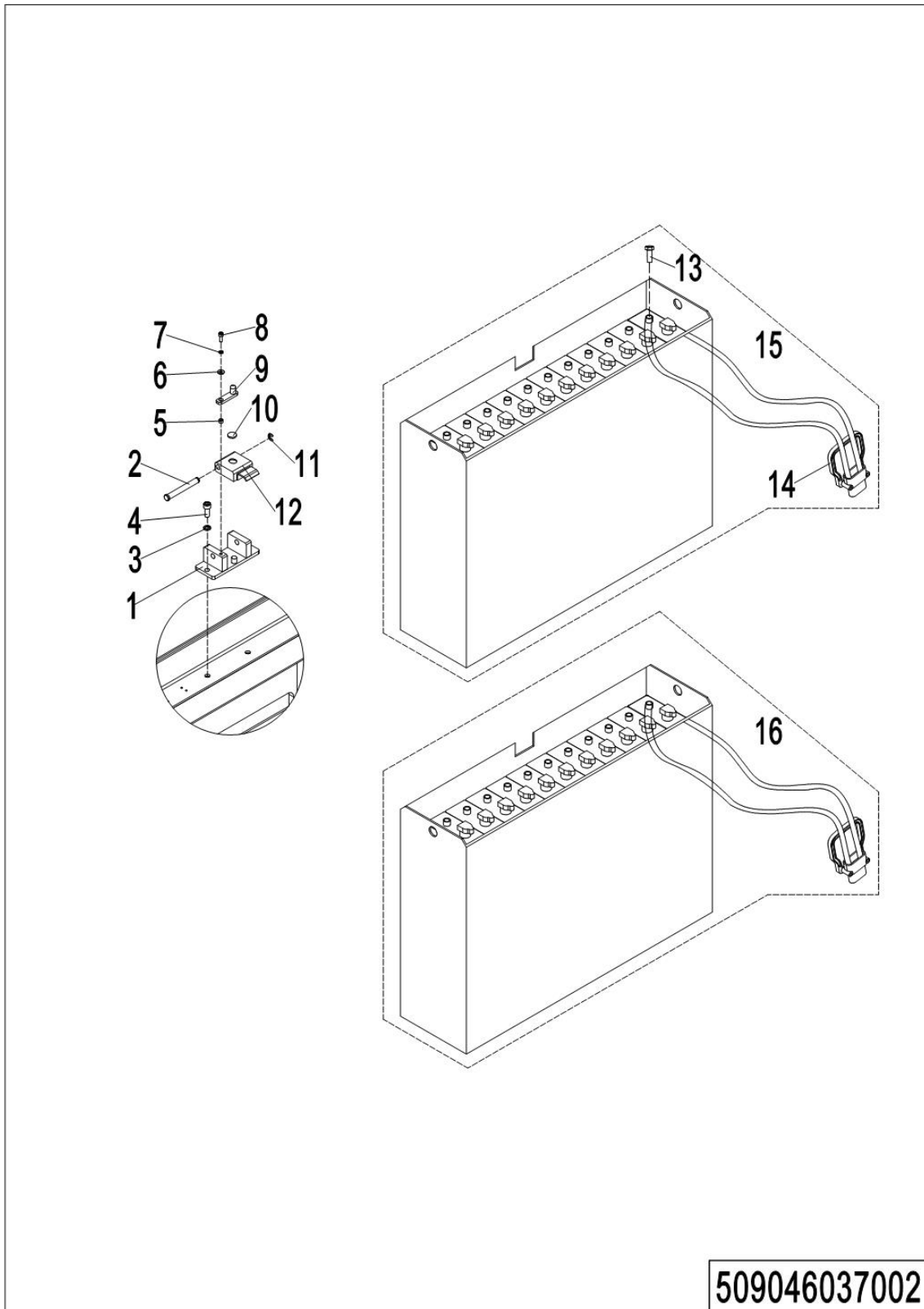
05 Lead acid (509046037002)

05 Lead acid (509046037002)

No.	Item Code	Mark	Item Description	Qty.	Substitute	Note
1	50572151000		Fixing Base	1		
2	50572152005		Pin	1		
3	91040050000		Spring Washer	2		
4	91020020007		Screw	2		
5	50572152005		Bushing	1		
6	50572152005		Washer	1		
7	91040050000		Spring Washer	1		
8	91020020003		Screw	1		
9	50572151000		Baffle	1		
10	94060010000		Magnetic Steel	1		
11	91040170000		Circlip	1		
12	50572151000		Stop Block	1		
13	50569852000		Bolt	24		
14	50579851001		Connector	1		
15	505737010002		Battery24V210Ah	1		
15	505737010004		Battery24V270Ah	1		
15	509537010000		Battery24V315Ah	1		
16	505737010001		Battery24V210Ah(welded)	1		
16	505737010003		Battery24V270Ah(welded)	1		

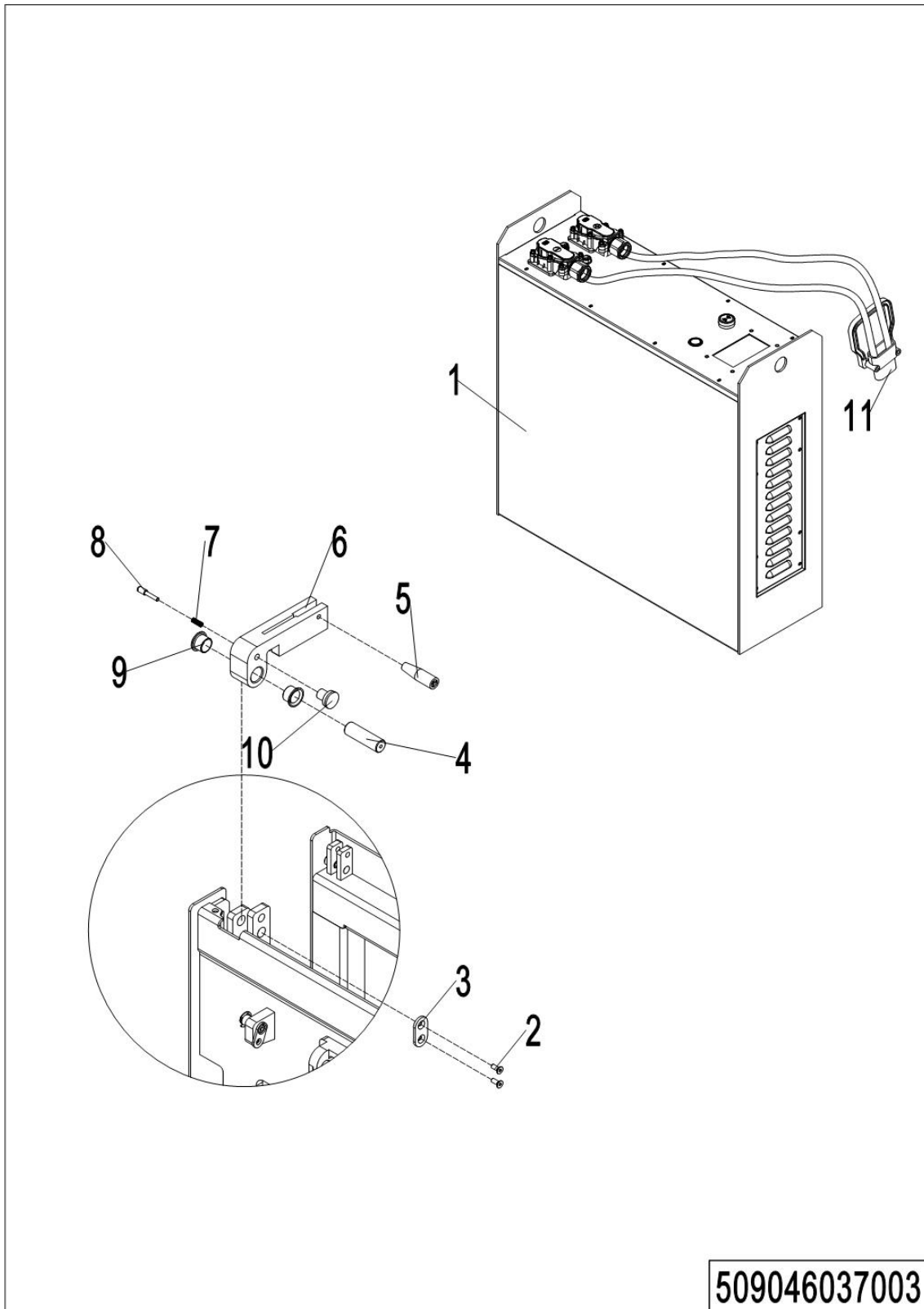
06 Lithium battery (509046037003)

06 Lithium battery (509046037003)

No.	Item Code	Mark	Item Description	Qty.	Substitute	Note
1	920600100143		Li Battery 24V200Ah	1		
2	910200400016		Screw	2		
3	505638520031		Fixing Plate	1		
4	506938520000		Axle	1		
5	911000400001		Tiller	1		
6	506738520040		Stop Block	1		
7	940400500001		Spring	1		
8	505638520122		Screw	1		
9	940500200008		Bushing	2		
10	505638520123		Handle	1		
11	920400100017		Connector	1		

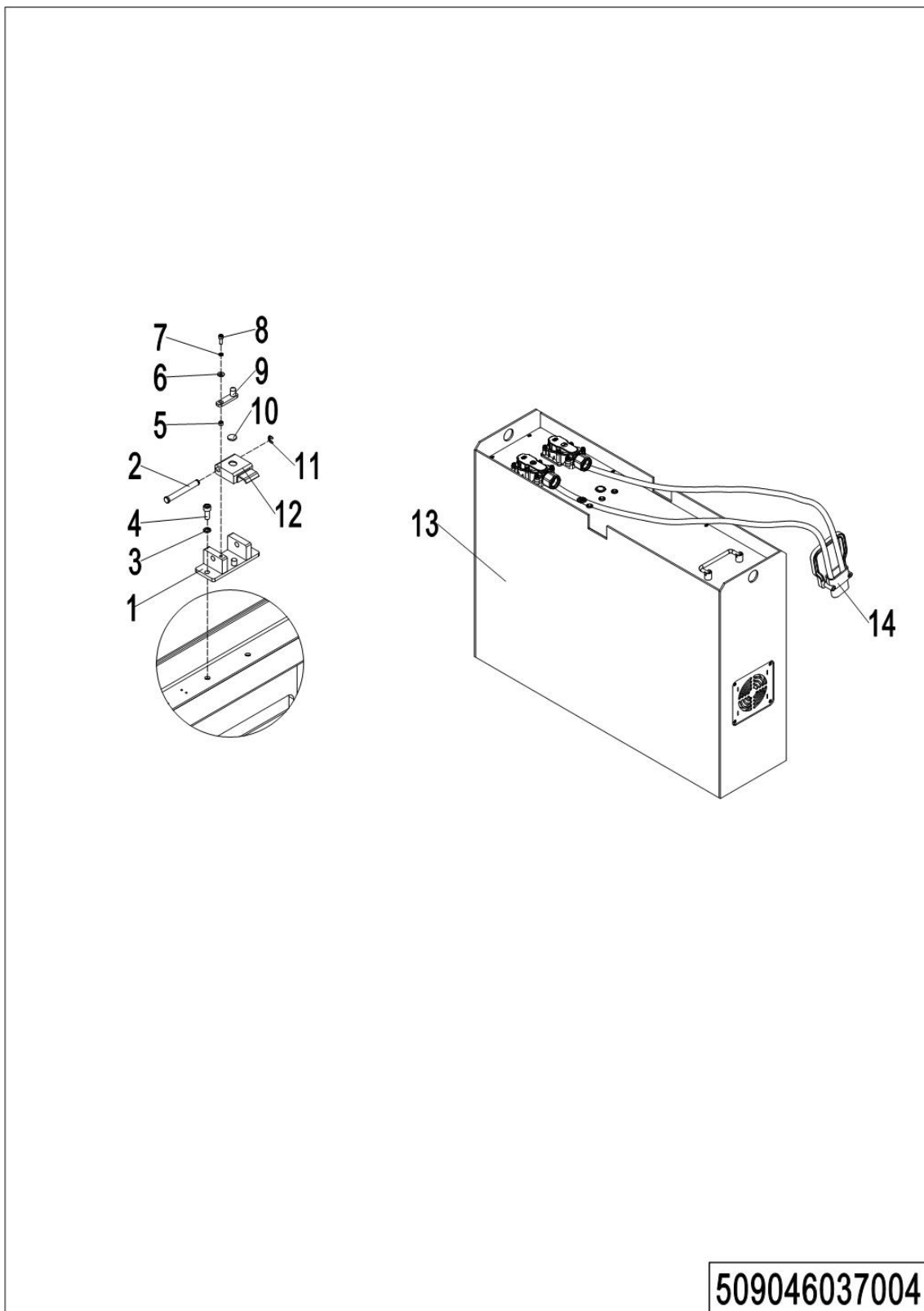
07 Lithium battery (509046037004)

07 Lithium battery (509046037004)

No.	Item Code	Mark	Item Description	Qty.	Substitute	Note
1	505721510007		Fixing Base	1		
2	505721520051		Pin	1		
3	910400500007		Spring Washer	2		
4	910200200076		Screw	2		
5	505721520053		Bushing	1		
6	505721520052		Washer	1		
7	910400500005		Spring Washer	1		
8	910200200035		Screw	1		
9	505721510008		Baffle	1		
10	940600100001		Magnetic Steel	1		
11	910401700003		Circlip	1		
12	505721510009		Stop Block	1		
13	920600100137		Li Battery 24V150Ah	1		
13	920600100104		Li Battery24V200Ah	1		
14	920400100017		Connector	1		

08 Controller, F2A +1220C (509046033001)

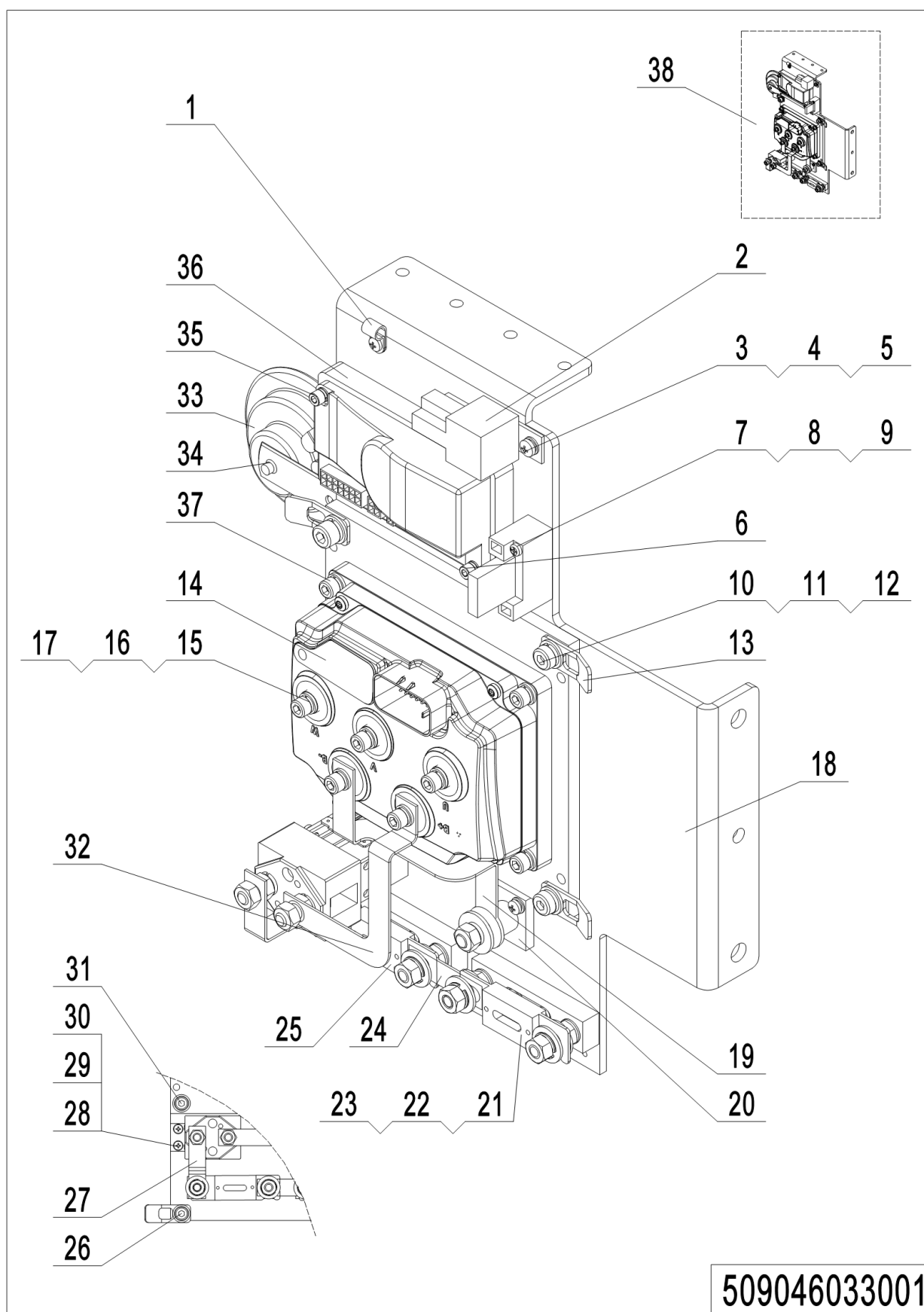

1=整包供货

2=限制供货

3=逐渐停止供货

4=不单件供货

5=见另外表单

08 Controller, F2A +1220C (509046033001)

序号	物料编码	Mark	物料名称	数量	替代零件号	说明
1	921300200002	2	Cable Clamp	1		
2	920800100011	2	Relay	1		
3	910200500034		Screw	4		
4	910400500003		Spring Washer	12		
5	910400100003		Flat Washer	12		
6	910200500028		Screw	1		
7	920100400006	2	Fuse Holder	1		
8	920100400006	2	Fuse Holder	1		
9	920100200002	2	Fuse 10A	1		
10	910200200057		Screw	3		
11	910400100006		Flat Washer	5		
12	910400500019		Spring Washer	6		
13	921300200012	2	Mounting Plate	4		
14	921400100064	2	Controller	1		
15	910200200035		Screw	5		
16	910400100005		Flat Washer	9		
17	910400500018		Spring Washer	9		
18	509021520043	2	Mounting Plate	1		
19	505633020007	2	Copper Busbar	1		
20	920100400001	2	Fuse Holder	1		
21	920100400009	2	Fuse Holder	2		
22	920100100004	2	Fuse Holder	1		
23	910200500024		Screw	4		
24	505633020003	2	Copper Busbar	1		
25	920100100007	2	Fuse 150A	1		
26	910200200051		Screw	1		
27	505633020002	2	Copper Busbar	1		
28	910200500020		Screw	2		
29	921300400001	2	Holder	1		
30	920700100004	2	Contacto	1		

1=整包供货

2=限制供货

3=逐渐停止供货

4=不单件供货

5=见另外表单

08 Controller, F2A +1220C (509046033001) Continuation

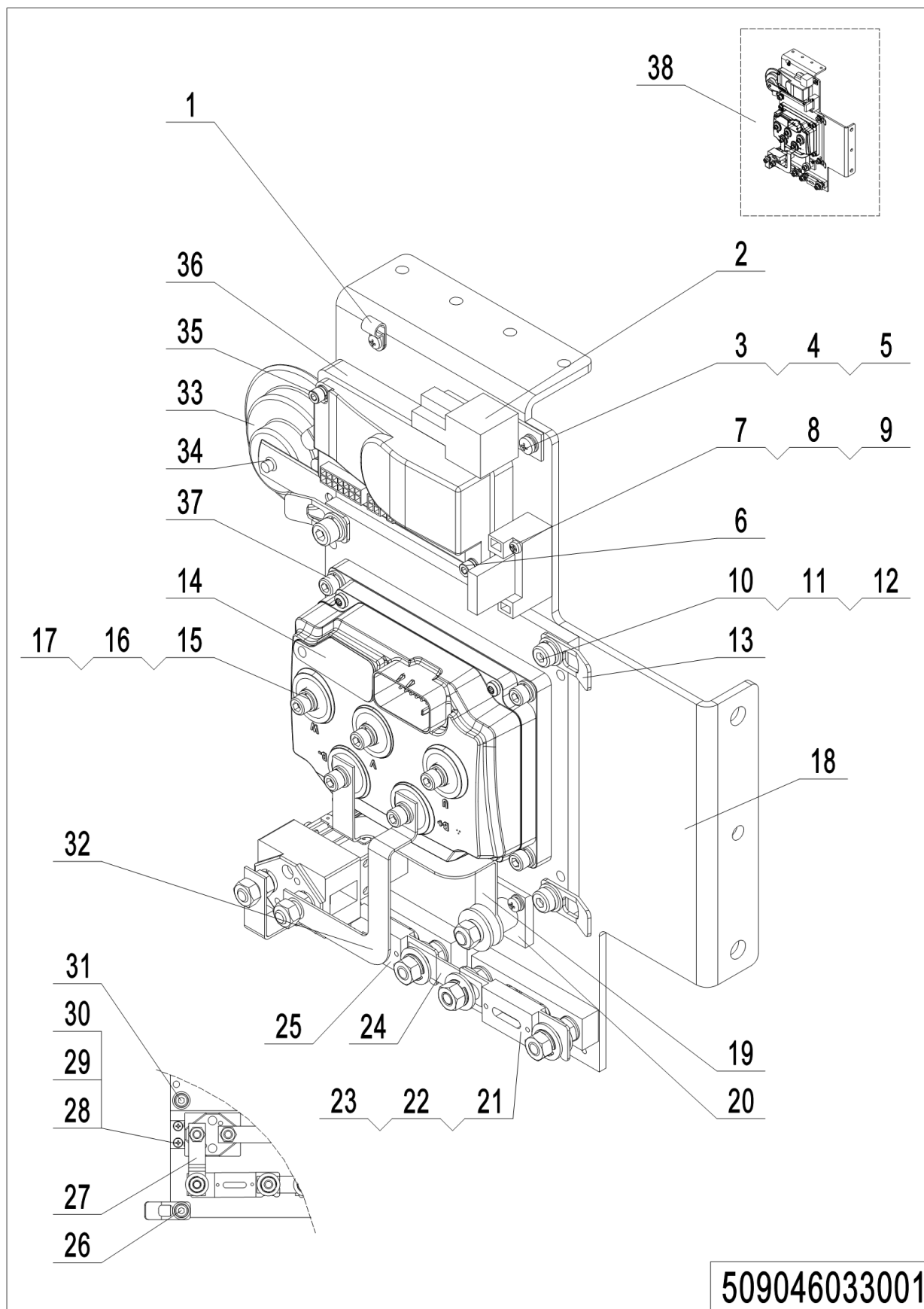

509046033001

1=整包供货

2=限制供货

3=逐渐停止供货

4=不单件供货

5=见另外表单

08 Controller, F2A +1220C (509046033001) Continuation

序号	物料编码	Mark	物料名称	数量	替代零件号	说明
31	910200200055		Screw	1		
32	505633020006	2	Copper Busbar	1		
33	920500100001	2	Horn	1		
34	910300100006		Nut	1		
35	910200500027		Screw	2		
36	921400100023	2	Controller	1		
37	910200200036		Screw	4		
38	509046033001	2	Electronic Control			

09 Controller, 1232E (509046033002)

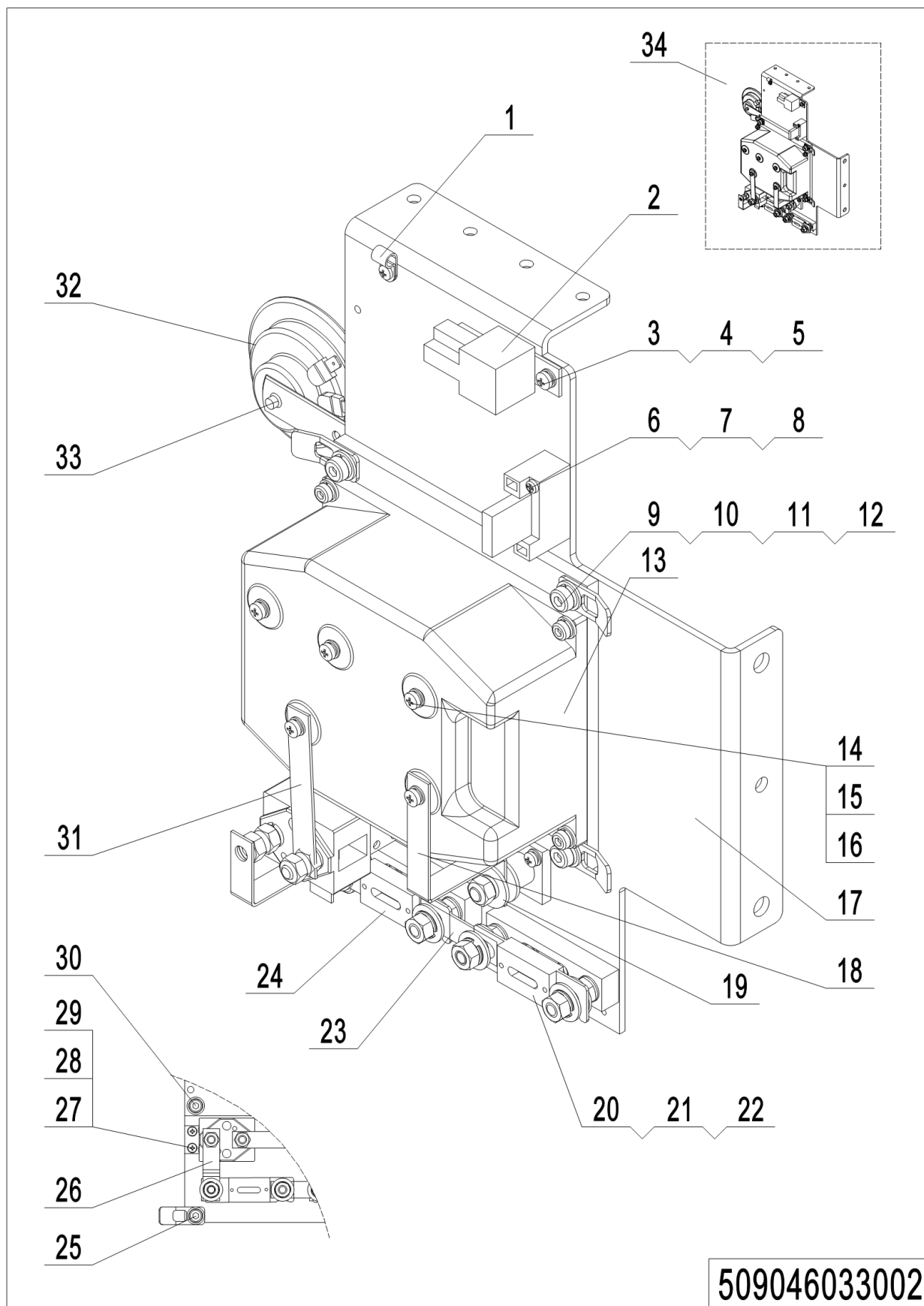

1=整包供货

2=限制供货

3=逐渐停止供货

4=不单件供货

5=见另外表单

09 Controller, 1232E (509046033002)

序号	物料编码	Mark	物料名称	数量	替代零件号	说明
1	921300200002	2	Cable Clamp	1		
2	920800100011	2	Relay	1		
3	910200500034		Screw	4		
4	910400500003		Spring Washer	12		
5	910400100003		Flat Washer	12		
6	920100400006	2	Fuse Holder	1		
7	910200500016		Screw	1		
8	920100200002	2	Fuse 10A	1		
9	910200200057		Screw	3		
10	910400100006		Flat Washer	5		
11	910400500019		Spring Washer	6		
12	921300200012	2	Mounting Plate	4		
13	921400100005	2	Controller	1		
14	910200200146		Screw	9		
15	910400100005		Flat Washer	9		
16	910400500018		Spring Washer	1		
17	509021520043	2	Mounting Plate	1		
18	505633020000	2	Copper Busbar	1		
19	920100400001	2	Fuse Holder	1		
20	920100400009	2	Fuse Holder	2		
21	920100100004	2	Fuse 80A	1		
22	910200500024		Screw	4		
23	505633020003	2	Copper Busbar	1		
24	920100100007	2	Fuse 150A	1		
25	910200200051		Screw	1		
26	505633020002	2	Copper Busbar	1		
27	910200500020		Screw	2		
28	921300400001	2	Holder	1		
29	920700100004	2	Contacto	1		
30	910200200055		Screw	1		

1=整包供货

2=限制供货

3=逐渐停止供货

4=不单件供货

5=见另外表单

09 Controller, 1232E (509046033002) Continuation

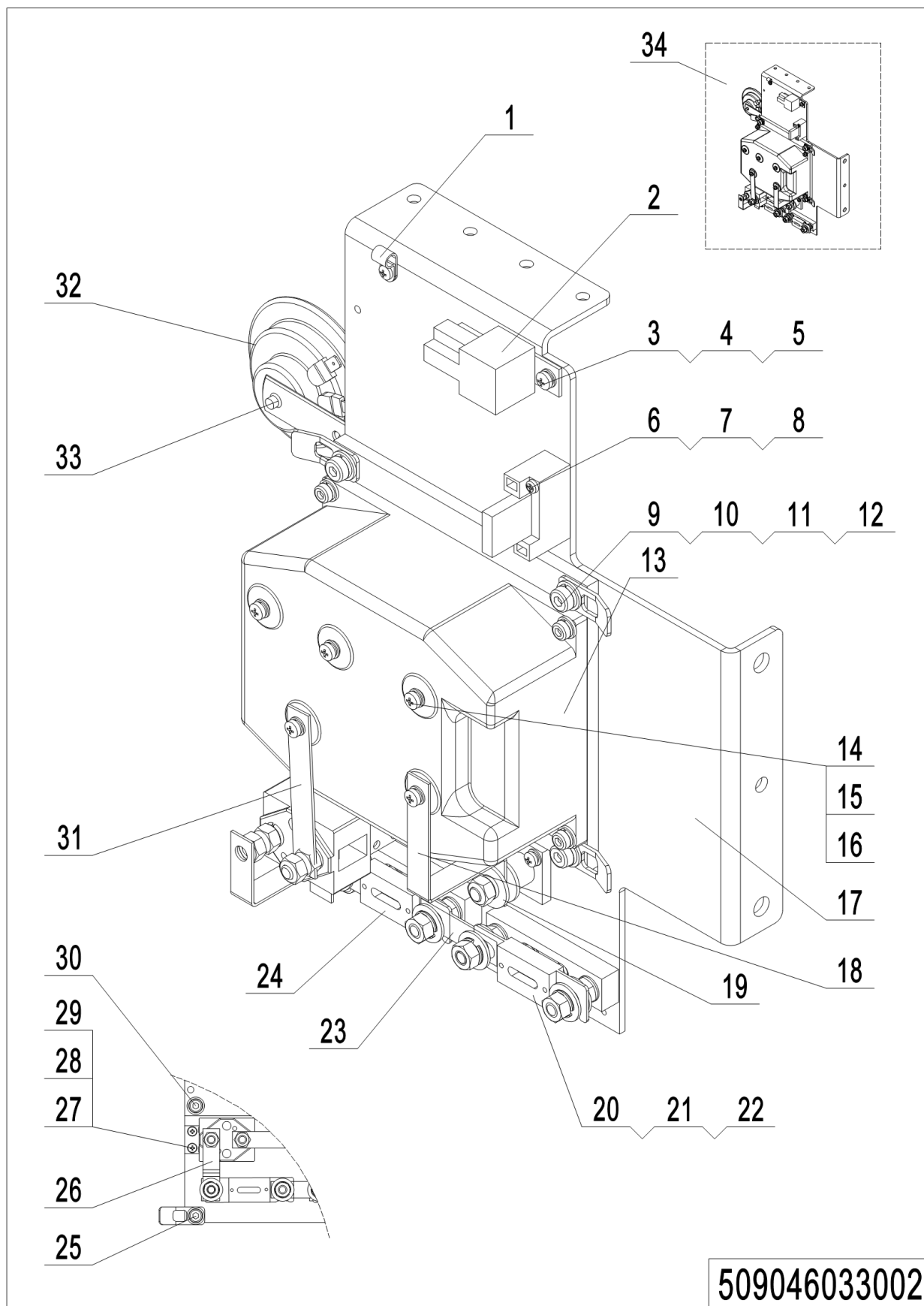

509046033002

1=整包供货

2=限制供货

3=逐渐停止供货

4=不单件供货

5=见另外表单

09 Controller, 1232E (509046033002) Continuation

序号	物料编码	Mark	物料名称	数量	替代零件号	说明
31	505633020001	2	Copper Busbar	1		
32	920500100001	2	Horn	1		
33	910300100006		Nut	1		
34	509046033002	2	Electronic Control	1		

10 Controller, 1232E +1220C (509046033003)

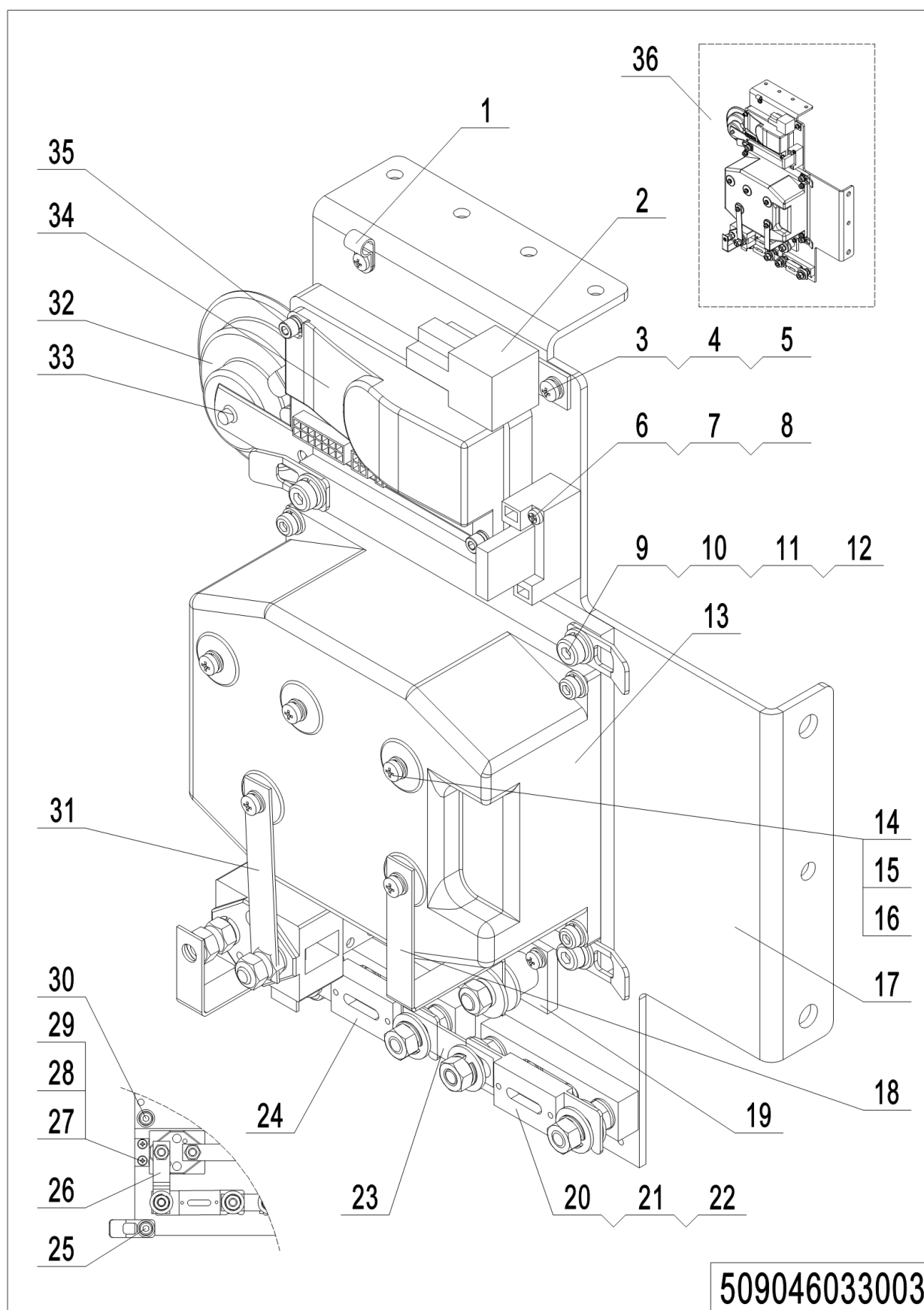

509046033003

1=整包供货

2=限制供货

3=逐渐停止供货

4=不单件供货

5=见另外表单

10 Controller, 1232E +1220C (509046033003)

序号	物料编码	Mark	物料名称	数量	替代零件号	说明
1	921300200002	2	Cable Clamp	1		
2	920800100011	2	Relay	1		
3	910200500034		Screw	4		
4	910400500003		Spring Washer	12		
5	910400100003		Flat Washer	12		
6	920100400006	2	Fuse Holder	1		
7	910200500016		Screw	1		
8	920100200002	2	Fuse 10A	1		
9	910200200057		Screw	3		
10	910400100006		Flat Washer	5		
11	910400500019		Spring Washer	6		
12	921300200012	2	Mounting Plate	4		
13	921400100005	2	Controller	1		
14	910200200146		Screw	9		
15	910400100005		Flat Washer	9		
16	910400500018		Spring Washer	1		
17	509021520043	2	Mounting Plate	1		
18	505633020000	2	Copper Busbar	1		
19	920100400001	2	Fuse Holder	1		
20	920100400009	2	Fuse Holder	2		
21	920100100004	2	Fuse 80A	1		
22	910200500024		Screw	4		
23	505633020003	2	Copper Busbar	1		
24	920100100007	2	Fuse 150A	1		
25	910200200051		Screw	1		
26	505633020002	2	Copper Busbar	1		
27	910200500020		Screw	2		
28	921300400001	2	Holder	1		
29	920700100004	2	Contacto	1		
30	910200200055		Screw	1		

1=整包供货

2=限制供货

3=逐渐停止供货

4=不单件供货

5=见另外表单

10 Controller, 1232E +1220C (509046033003) Continuation

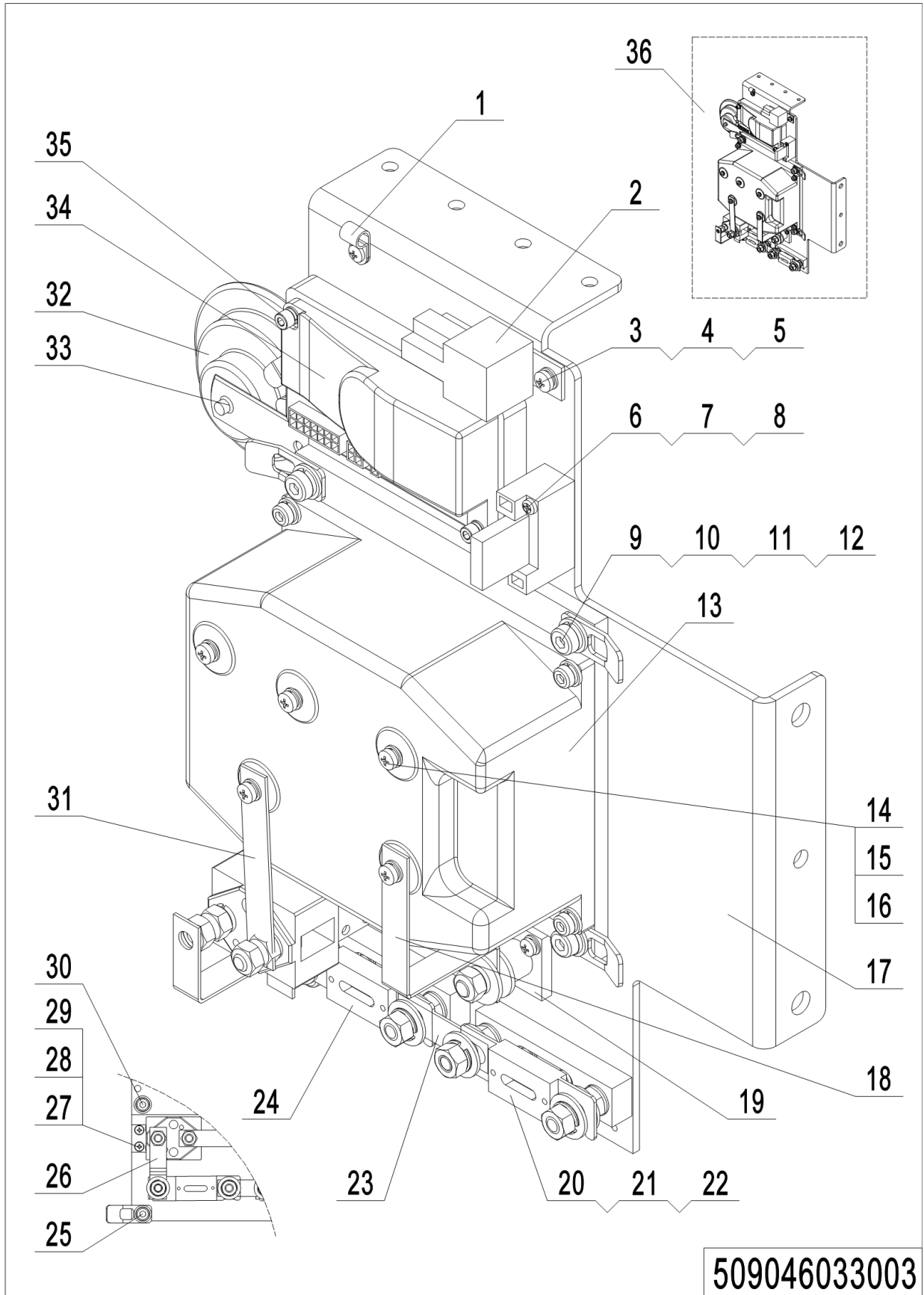

509046033003

1=整包供货

2=限制供货

3=逐渐停止供货

4=不单件供货

5=见另外表单

10 Controller, 1232E +1220C (509046033003) Continuation

序号	物料编码	Mark	物料名称	数量	替代零件号	说明
31	505633020001	2	Copper Busbar	1		
32	920500100001	2	Horn	1		
33	910300100006		Nut	1		
34	921400100023	2	Control	1		
35	910200500027		Screw	2		
36	509046033003	2	Electronic Control	1		

11 Controller, QT (509046033004)

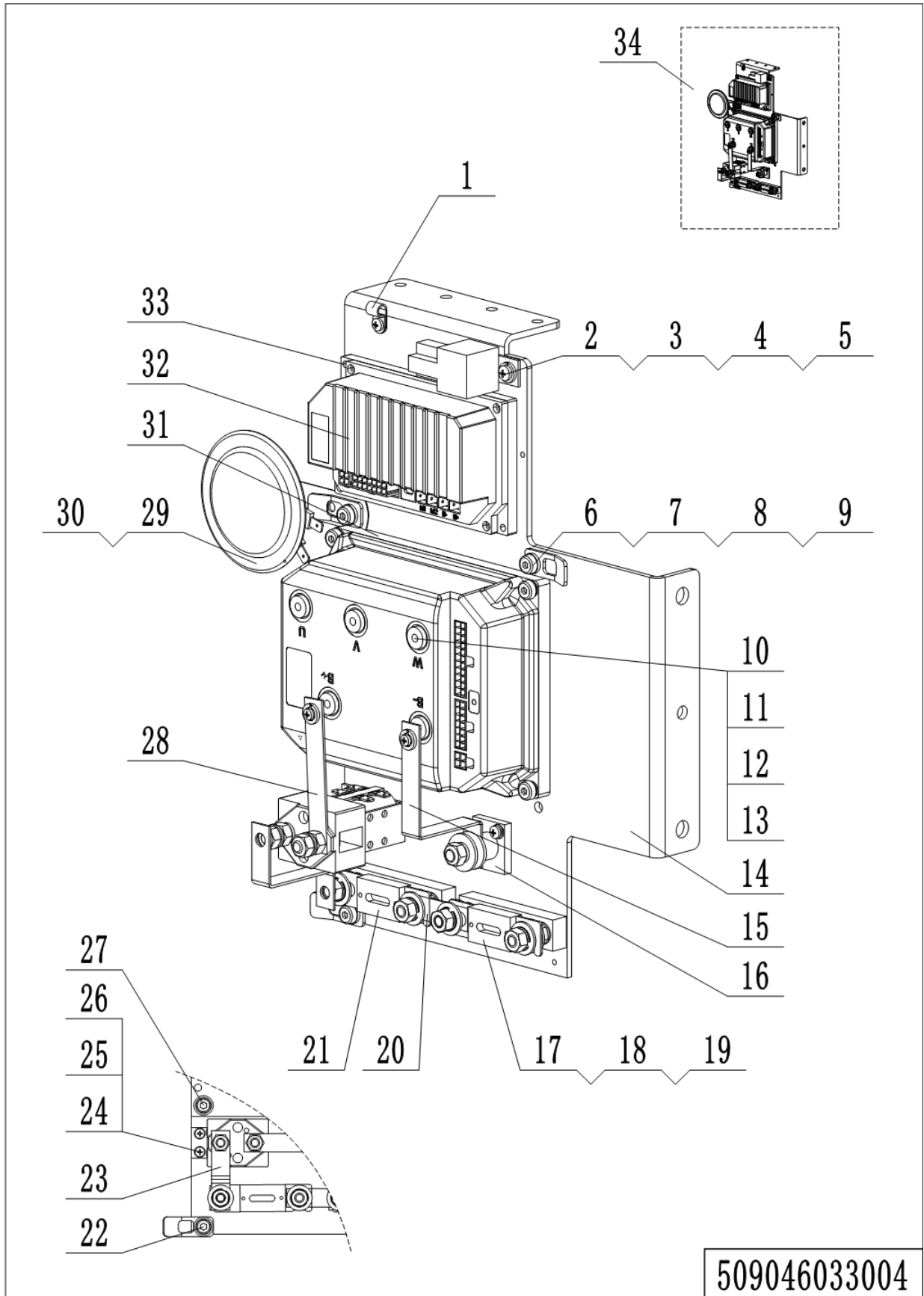

509046033004

1=整包供货

2=限制供货

3=逐渐停止供货

4=不单件供货

5=见另外表单

11 Controller, QT (509046033004)

序号	物料编码	Mark	物料名称	数量	替代零件号	说明
1	921300200002	2	Cable Clamp	1		
2	920800100011	2	Relay	1		
3	910200500034		Screw	2		
4	910400500003		Spring Washer	10		
5	910400100003		Flat Washer	10		
6	910200200057		Screw	3		
7	910400100006		Flat Washer	5		
8	910400500019		Spring Washer	5		
9	921300200012	2	Mounting Plate	1		
10	921400100131	2	Controller LVM24S20	1		PT20、25P-C
10	921400100132	2	Controller LVM24S25	1		PT30P-C
11	910200200146		Screw	9		
12	910400100005		Flat Washer	9		
13	910400500018		Spring Washer	9		
14	509021520062	2	Mounting Plate	1		
15	505633020000	2	Copper Busbar	1		
16	920100400001	2	Fuse Holder	1		
17	920100400009	2	Fuse Holder	1		
18	920100100007	2	Fuse 150A	1		
19	910200500024		Screw	4		
20	505633020003	2	Copper Busbar	1		
21	920100100004	2	Fuse 80A	1		PT20P-C
21	920100100007	2	Fuse 150A	1		25P-C、PT30P-C
22	910200200051		Screw	1		
23	505633020002	2	Copper Busbar	2		
24	910200500020		Screw	2		
25	921300400001	2	Holder	1		
26	920700100004	2	Contactactor	1		
27	910200200055		Screw	1		
28	505633020001	2	Copper Busbar	1		

1=整包供货

2=限制供货

3=逐渐停止供货

4=不单件供货

5=见另外表单

11 Controller, QT (509046033004) Continuation

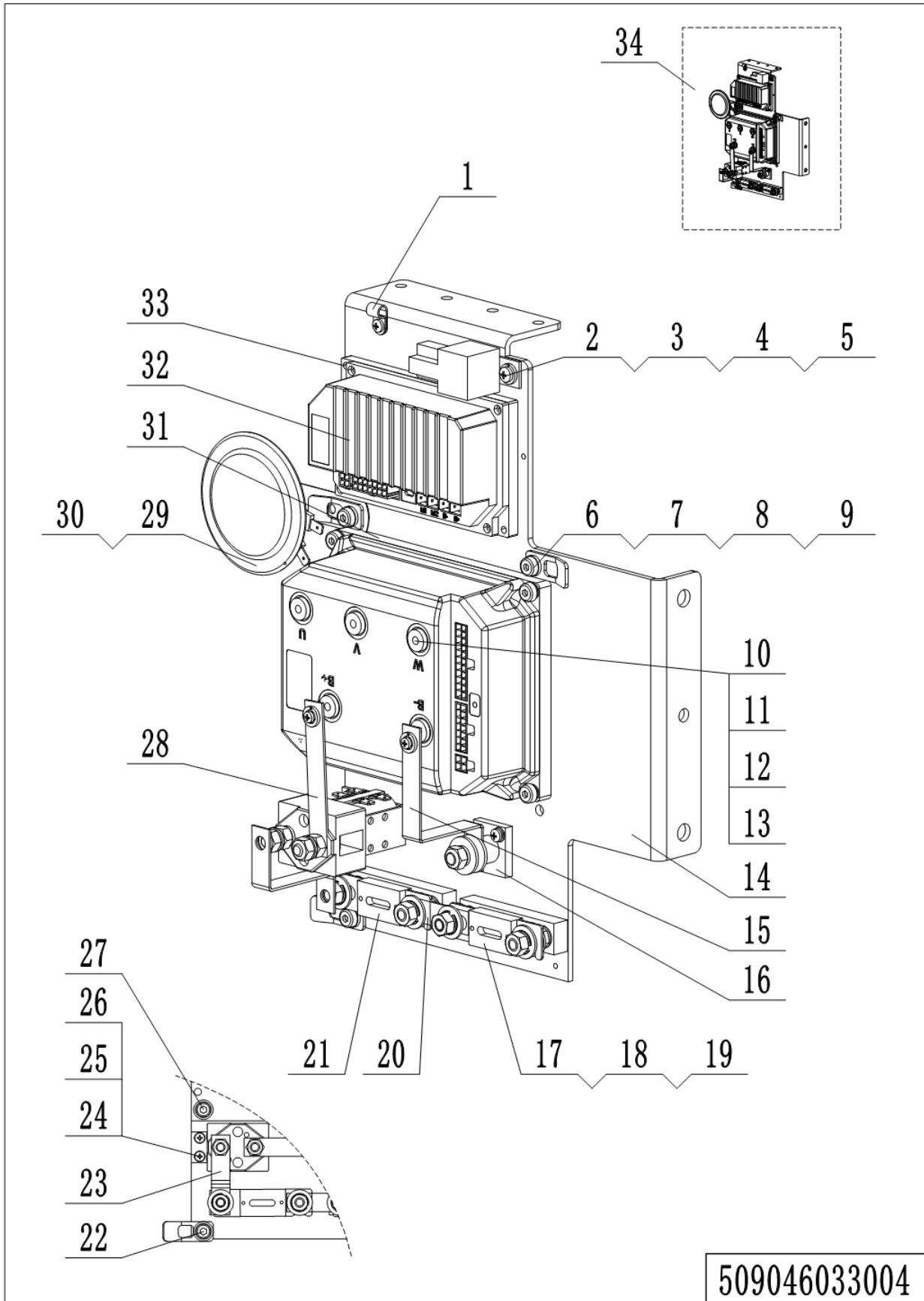

509046033004

11 Controller, QT (509046033004) Continuation

序号	物料编码	Mark	物料名称	数量	替代零件号	说明
29	920500100001	2	Horn	1		
30	910300100006		Nut	1		
31	505633020005	2	Plate	1		
32	921400100134	2	Controller DVM24S04	1		
33	910200500027		Screw	2		
34	509046033004	2	Electronic Control	1		

12 Wire Harness, F2A +1220C (509046033005)

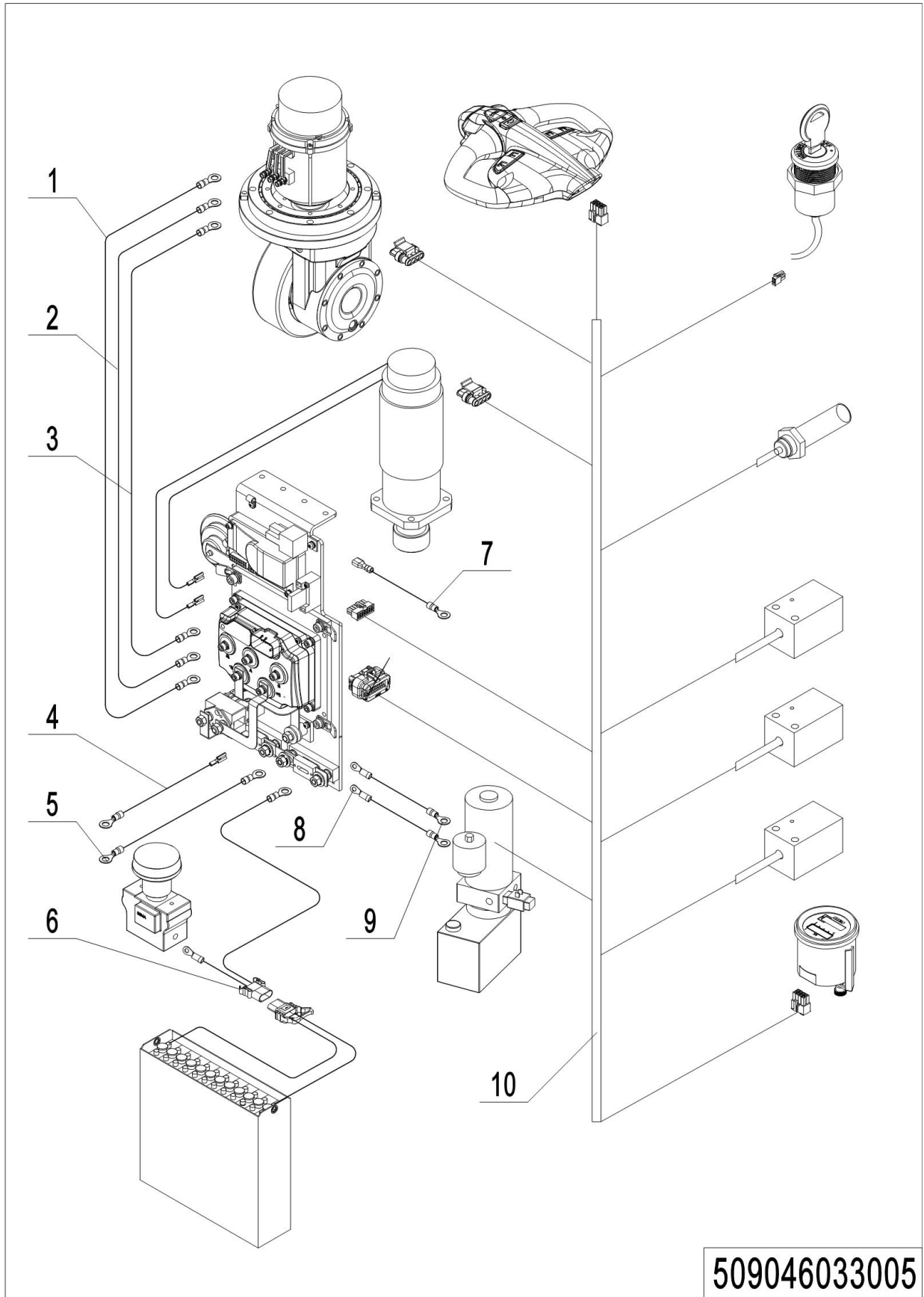

509046033005

12 Wire Harness, F2A +1220C (509046033005)

No.	Item Code	Mark	Item Description	Qty.	Substitute	Note
1	509033010002		Cable	1		
2	509033010003		Cable	1		
3	509033010004		Cable	1		
4	509033010016		Wire Harness	1		
5	509033010008		Cable	1		
6	509033010013		Wire Harness	1		
7	509033010014		Cables	1		
8	509533010003		Cable	1		
9	509533010004		Cable	1		
10	509033010001		Wire Harness	1		

13 Wire Harness, 1232E+Li (509046033006)

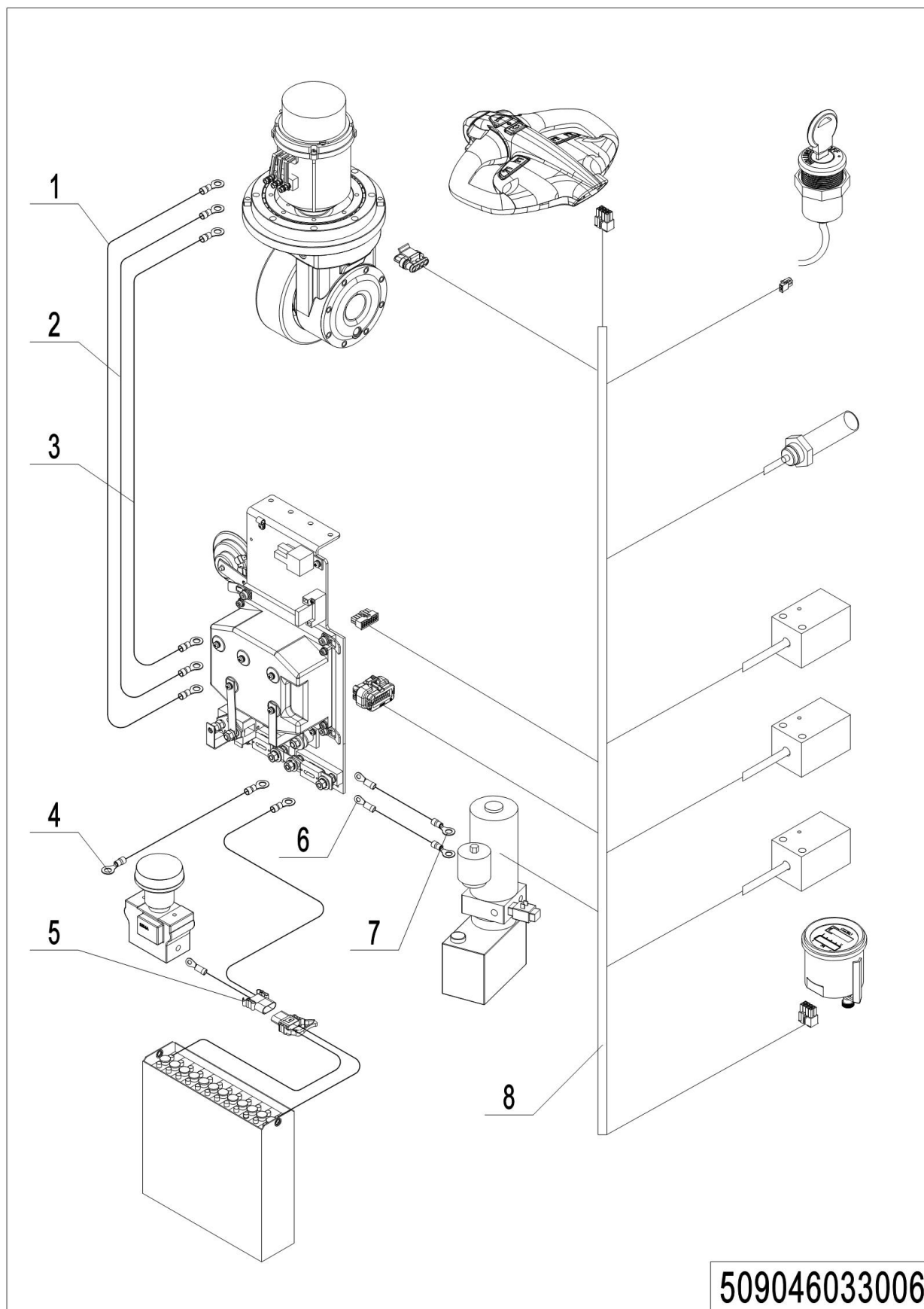

509046033006

1=整包供货

2=限制供货

3=逐渐停止供货

4=不单件供货

5=见另外表单

13 Wire Harness, 1232E+Li (509046033006)

No.	Item Code	Mark	Item Description	Qty.	Substitute	Note
1	509033010015		Cable	1		
2	509033010022		Cable	1		
3	509033010023		Cable	1		
4	509033010008		Cable	1		
5	509033010025		Wire Harness	1		Li
6	509033010024		Cable	1		
7	509533010004		Cable	1		
8	509033010012		Wire Harness	1		

14 Wire Harness, QT (509046033001)

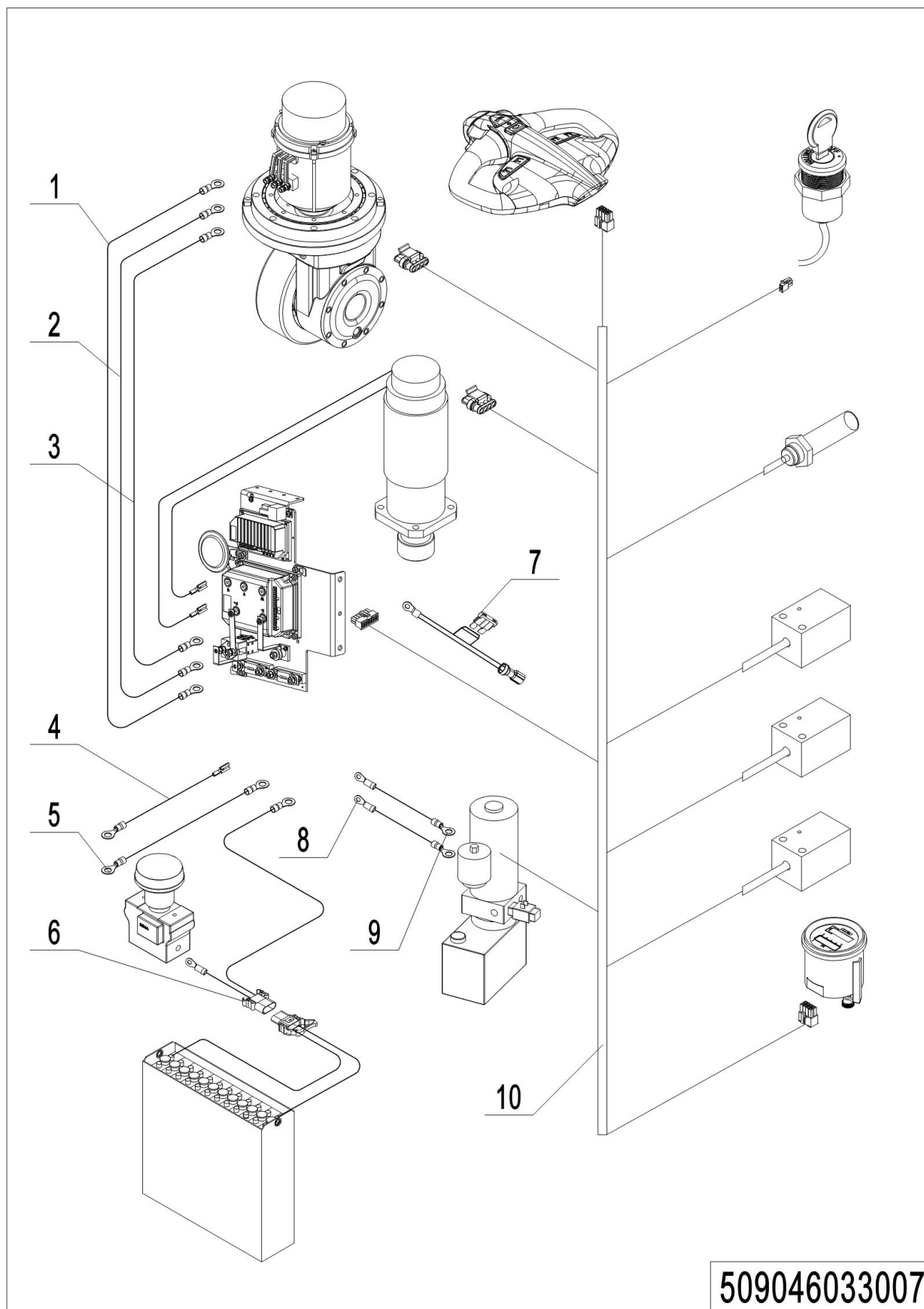

509046033007

1=整包供货

2=限制供货

3=逐渐停止供货

4=不单件供货

5=见另外表单

14 Wire Harness, QT (509046033007)

No.	Item Code	Mark	Item Description	Qty.	Substitute	Note
1	509033010002		Cable -U-16-6-6-730	1		
2	509033010003		Cable -V-16-6-6-760	1		
3	509033010004		Cable -W-16-6-6-800	1		
4	509033010014		Cable -2B--4-6. 3-8-400	1		
5	509033010008		Cable -FU+-25-8-8-800	1		
6	509033010013		Total power harness	1		
6	509033010025		Total power harness+Li	1		Li
7	509033010016		EPS Fuse Harness	1		
8	509533010003		Cable -FP-16-8-8-1100	1		
9	509533010004		Cable -E2-16-8-8-1200	1		
10	509533010009		Control Harness	1		
10	509533010006		Control Harness+Li	1		Li

15 Wire Harness, 1232E+1220C+ Fixed (509546033001)

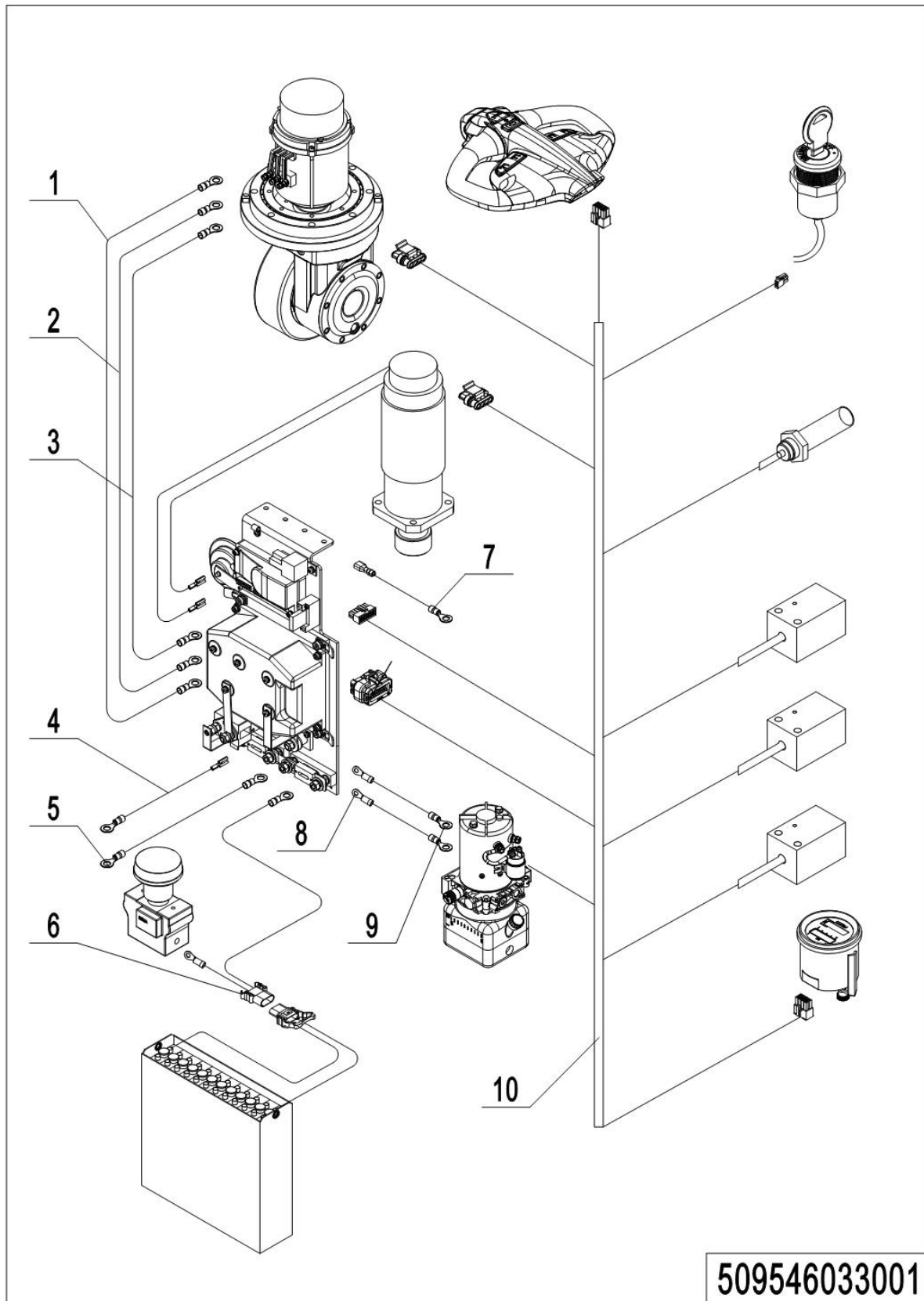

1=整包供货

2=限制供货

3=逐渐停止供货

4=不单件供货

5=见另外表单

15 Wire Harness, 1232E+1220C+ Fixed (509546033001)

No.	Item Code	Mark	Item Description	Qty.	Substitute	Note
1	509033010002		Cable	1		
2	509033010003		Cable	1		
3	509033010004		Cable	1		
4	509033010016		Wire Harness	1		
5	509033010008		Cable	1		
6	509033010013		Wire Harness	1		
6	509033010025		Wire Harness	1		Li
7	509033010014		Cables	1		
8	509533010003		Cable	1		
9	509533010004		Cable	1		
10	509533010002		Wire Harness	1		
10	509533010000		Wire Harness	1		Li

Chapter 7: Special Parts

01 Guard Arm (505646017501)

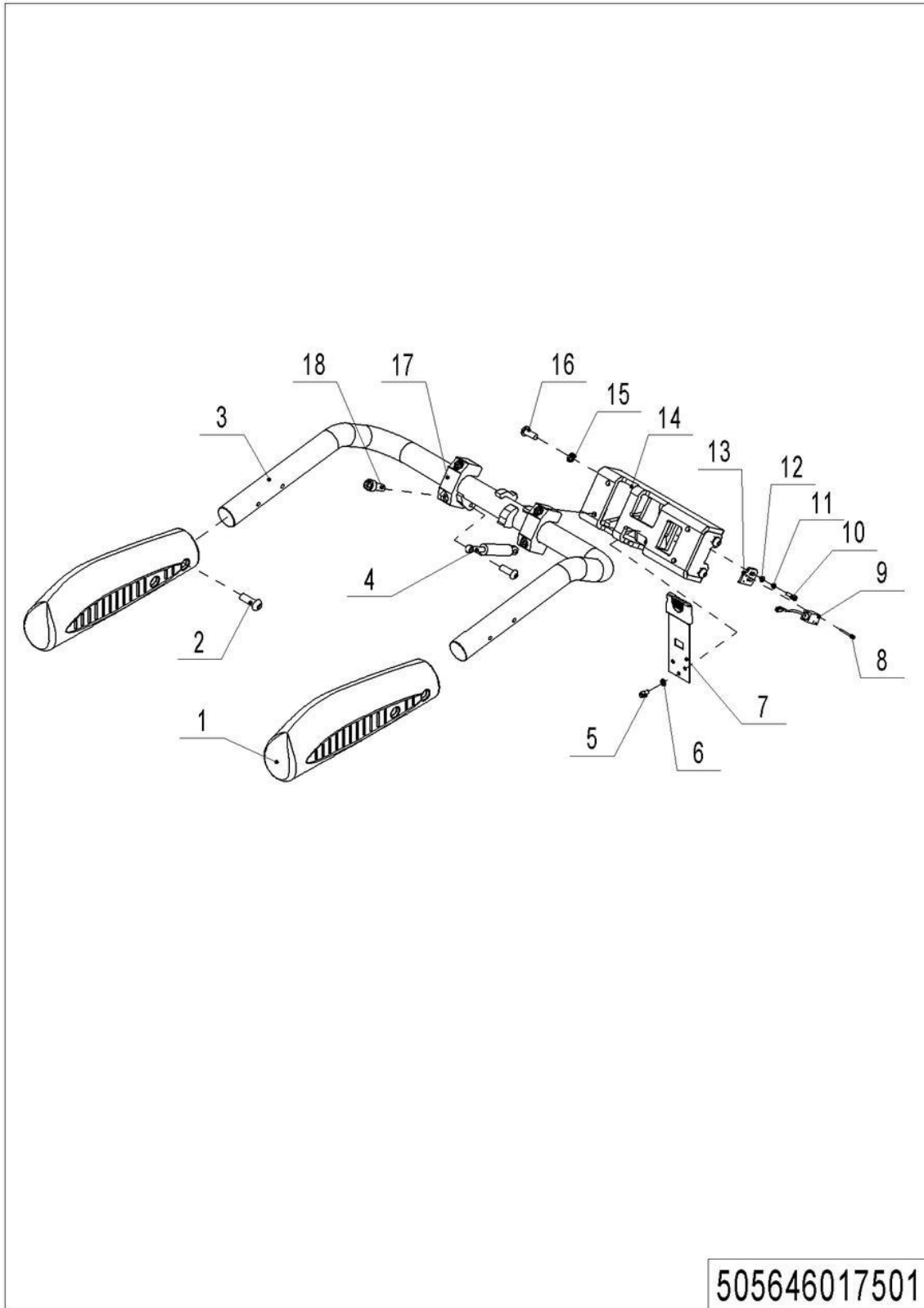

1=整包供货

2=限制供货

3=逐渐停止供货

4=不单件供货

5=见另外表单

01 Guard Arm (505646017501)

No.	Item Code	Mark	Item Description	Qty.	Substitute	Note
1	505617510002		Guard Arm Sleeve	2		
2	910200300025	1	Screw	5		
3	505617510001		Guard Arm	1		
4	940400100006		Air Spring	1		
5	910200300017	1	Screw	3		
6	910400500005	1	Spring Washer	3		
7	505617510005		Leaf Spring	1		
8	910200500015	1	Screw	2		
9	505633510001	2	Proximity Switch	1		
10	910400500004	1	Spring Washer	2		
11	910400100004	1	Flat Washer	2		
12	910200200023	1	Screw	2		
13	532617520001		Mounting Plate	1		
14	505617510000		Base	1		
15	910400500007	1	Spring Washer	4		
16	910100300036	1	Bolt	4		
17	505617520005		Fixing Base	2		
18	910200200080	1	Screw	4		
--	505698510012		Protective Arm	1		

02 Platform (505646018001)

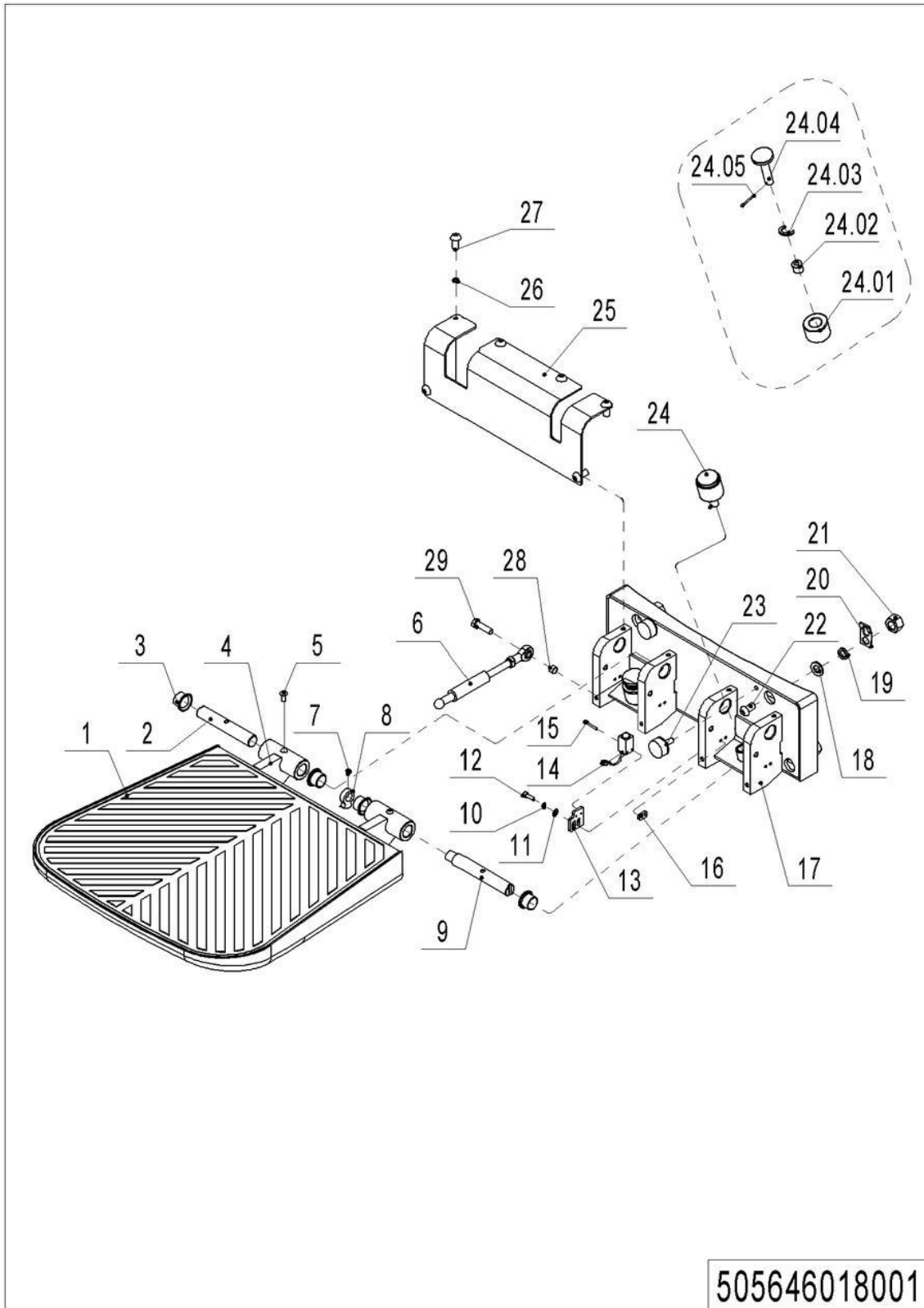

1=整包供货

2=限制供货

3=逐渐停止供货

4=不单件供货

5=见另外表单

02 Platform (505646018001)

No.	Item Code	Mark	Item Description	Qty.	Substitute	Note
1	505618020018		Rubber Mat	1		
2	505618020020		Axle	1		
3	940500200008		Bushing	4		
4	505618010000		Platform	1		
5	910200300018	1	Screw	2		
6	940400100039		Air Spring	1		
7	910300400006		Nut	1		
8	505618020024		Cam	1		
9	505618020017		Pin	1		
10	910400500004	1	Spring Washer	2		
11	910400100004	1	Flat Washer	2		
12	910200200023	1	Screw	2		
13	505618020026		Mounting Plate	1		
14	505633510002	2	Proximity Switch	1		
15	910200500015	1	Screw	2		
16	505618020027		Mounting Plate	1		
17	505618010001		Mounting Base	1		
18	910400100008	1	Flat Washer	4		
19	910400500008	1	Spring Washer	4		
20	505618020025		Pipe Clip	1		
21	910300500006	1	Nut	4		
22	910200200100	1	Screw	4		
23	505618020016		Crash Pad	2		
24	505698510002		Buffer Kits	2		
24.01	505618020029		Crash Pad	2		
24.02	505618020030		Sleeve	2		
24.03	505618020032		Pad	2		
24.04	505618020021		Pin	2		
24.05	910600600026	1	Cotter Pin	2		
25	505618020019		Protective Cover	1		

1=整包供货

2=限制供货

3=逐渐停止供货

4=不单件供货

5=见另外表单

02 Platform (505646018001) Continuation

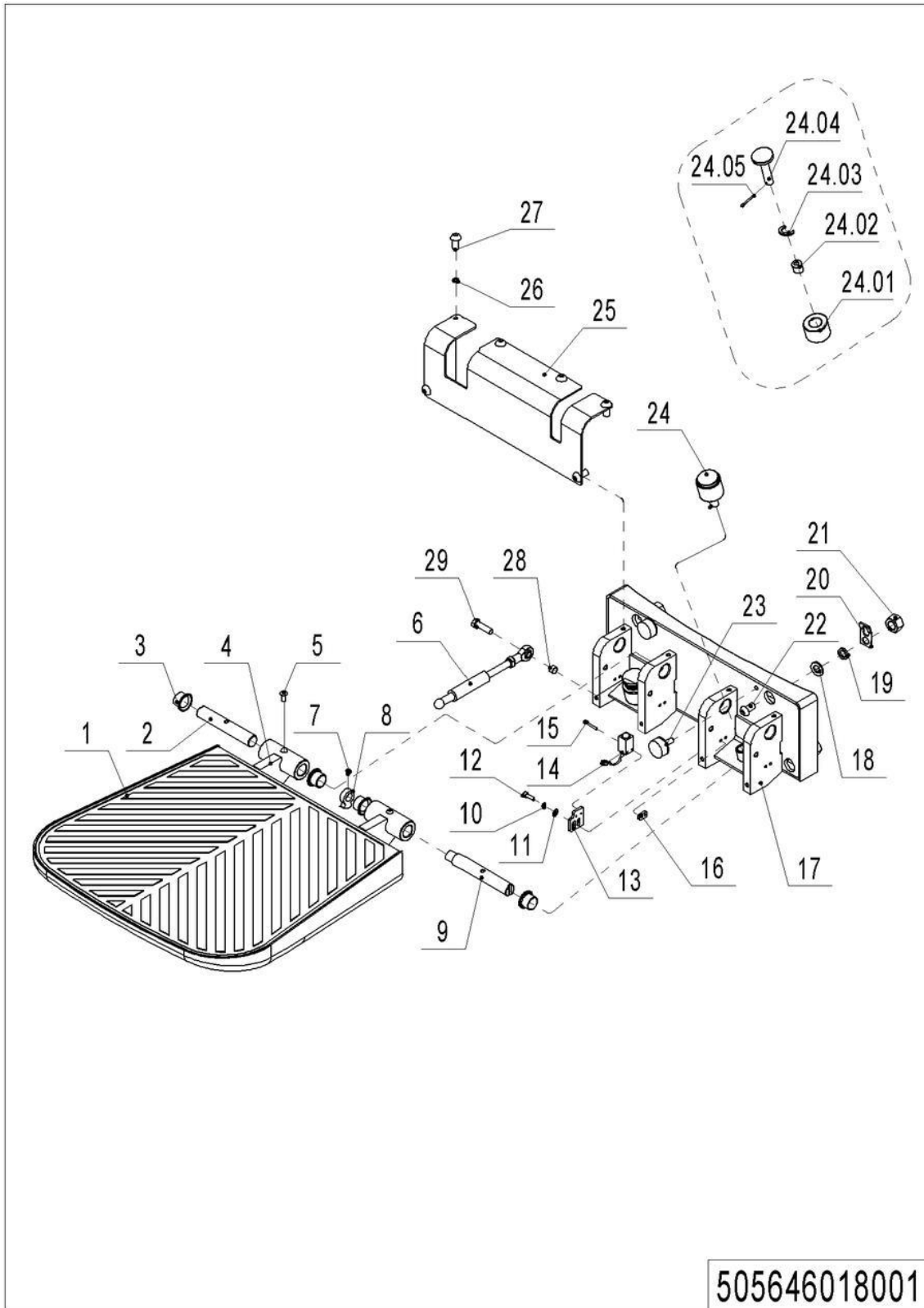

1=整包供货

2=限制供货

3=逐渐停止供货

4=不单件供货

5=见另外表单

02 Platform (505646018001) Continuation

No.	Item Code	Mark	Item Description	Qty.	Substitute	Note
26	910400500005	1	Spring Washer	6		
27	910200300017	1	Screw	6		
28	505618020028		Spacer Bush	1		
29	910100300024	1	Bolt	1		
--	505698510013		Footboard Kit	1		

Chapter 8: Others

01 Labels, Decals-EU (509046047001)

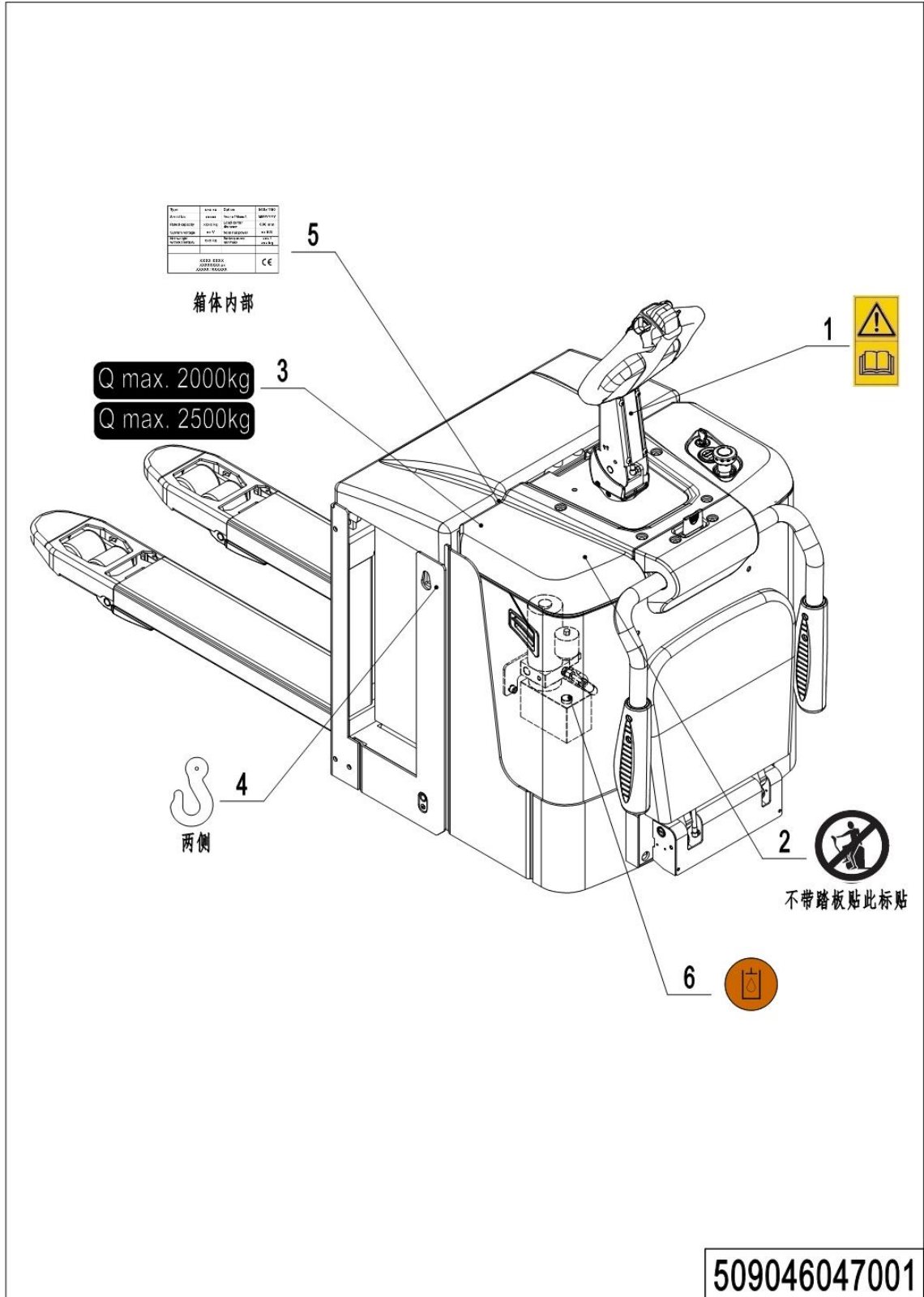

1=整包供货

2=限制供货

3=逐渐停止供货

4=不单件供货

5=见另外表单

01 Labels, Decals-EU (509046047001)

No.	Item Code	Mark	Item Description	Qty.	Substitute	Note
1	941200300002		Label	1		
2	941200100003		Label	1		
3	941200200010		Label	1		
3	941200200011		Label	1		
4	941200300001		Label	2		
5	505647020001		Truck data plate	1		
6	941200300003		Label	1		

02 Labels, Decals-US (509046047002)

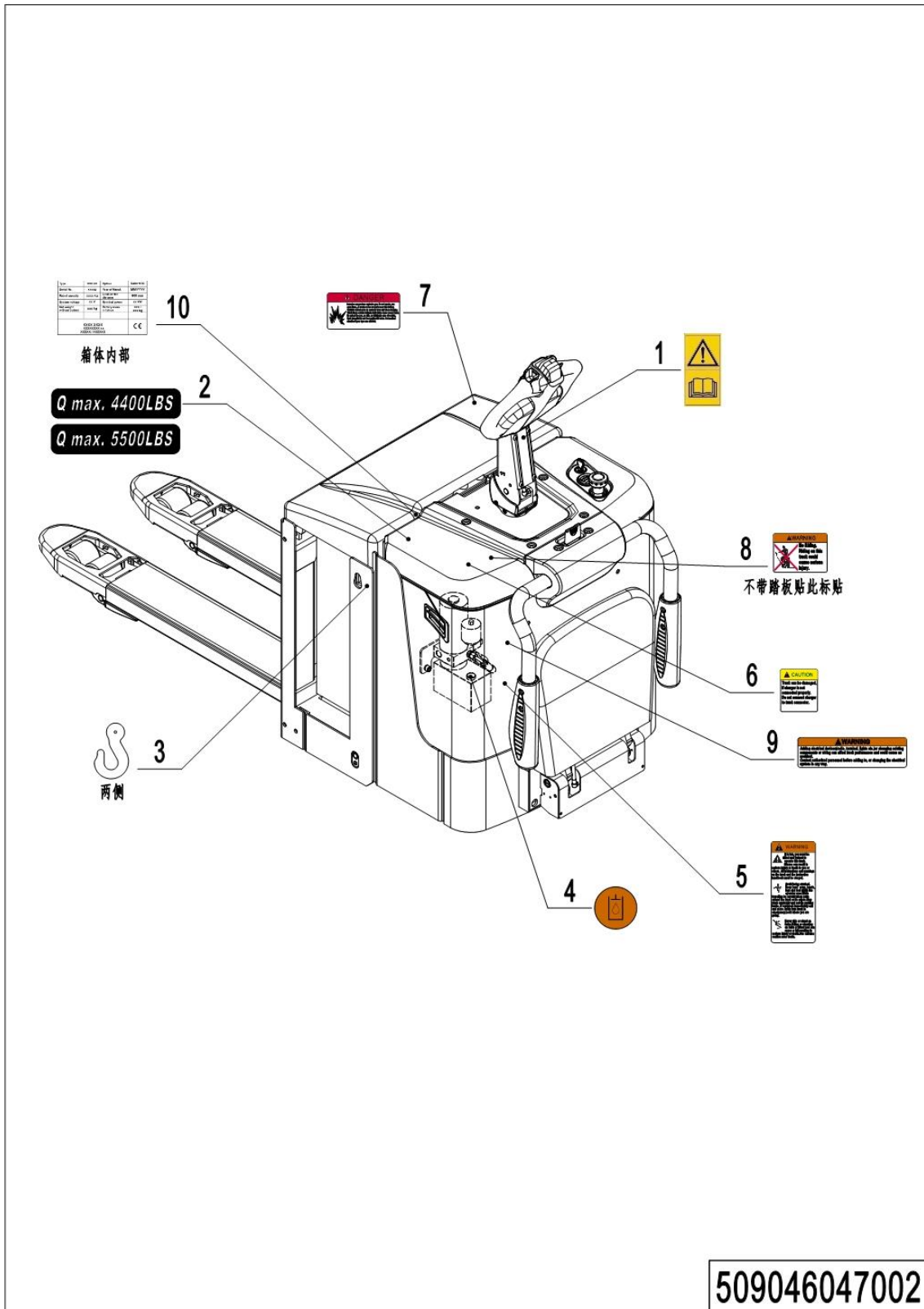

02 Labels, Decals-US (509046047002)

No.	Item Code	Mark	Item Description	Qty.	Substitute	Note
1	941200300002		Label	1		
2	941200200038		Label	1		
2	941200200039		Label	1		
3	941200300001		Label	2		
4	941200300003		Label	1		
5	941200100009		Label	1		
6	941200100012		Label	1		
7	941200100013		Label	1		
8	941200100011		Label	1		
9	941200100010		Label	1		
10	505647020002		Truck data plate	1		

03 Labels, Decals-EU, Fixed (509046047003)

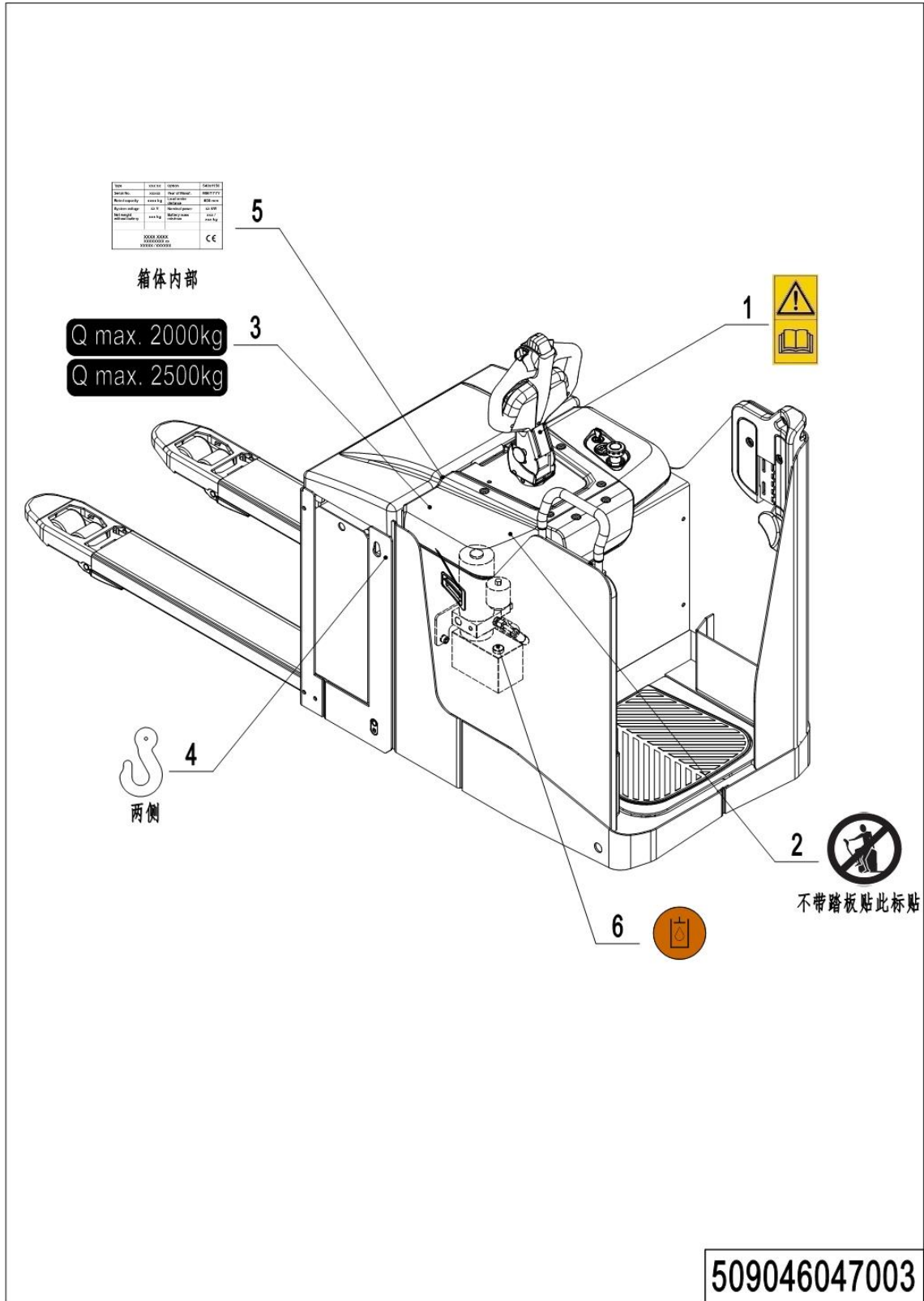

1=整包供货

2=限制供货

3=逐渐停止供货

4=不单件供货

5=见另外表单

03 Labels, Decals-EU, Fixed (509046047003)

No.	Item Code	Mark	Item Description	Qty.	Substitute	Note
1	941200300002		Label	1		
2	941200100003		Label	1		
3	941200200010		Label	1		
3	941200200011		Label	1		
4	941200300001		Label	2		
5	505647020001		Truck data plate	1		
6	941200300003		Label	1		

04 Labels, Decals-US, Fixed (509046047004)

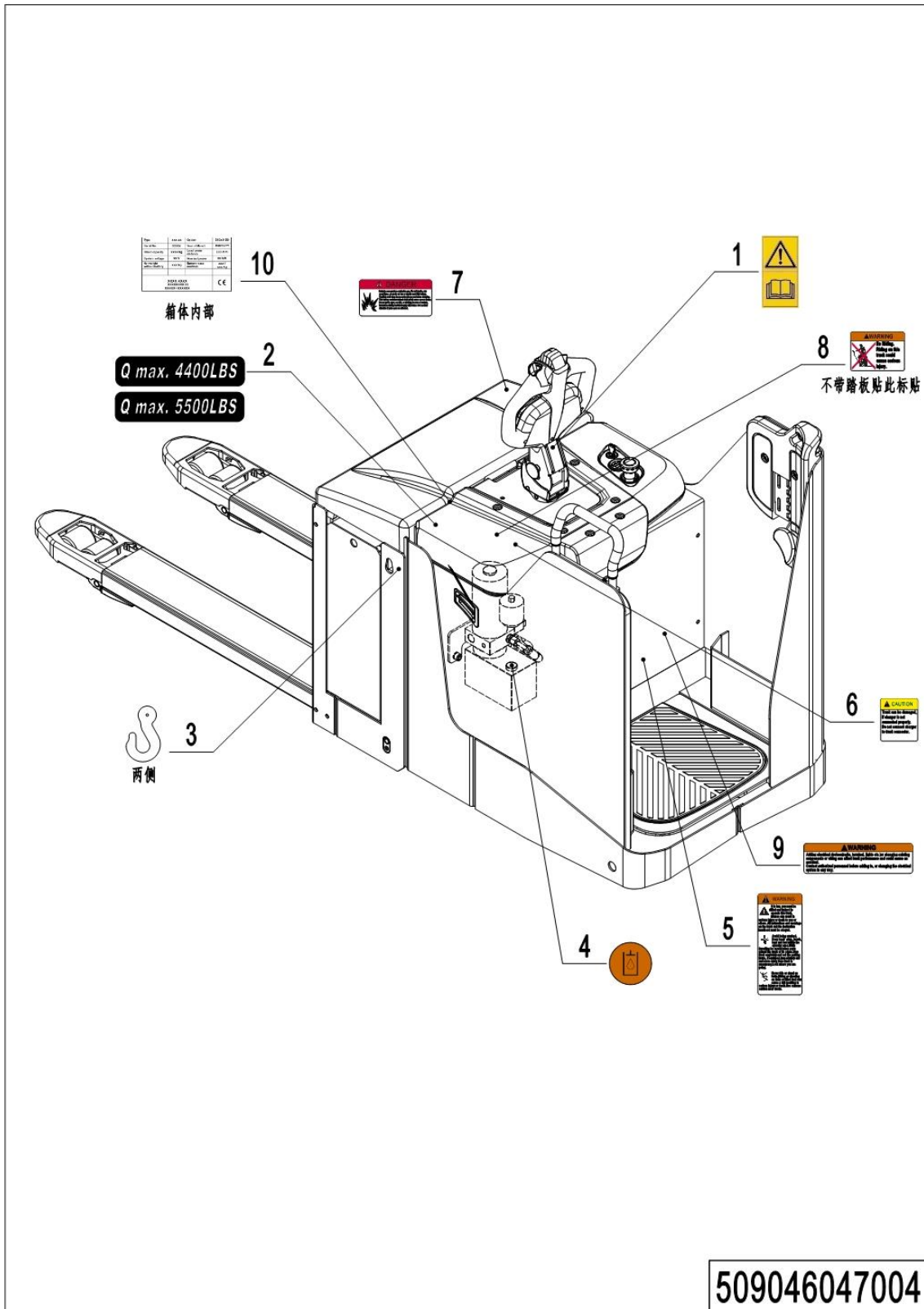

04 Labels, Decals-US, Fixed (509046047004)

No.	Item Code	Mark	Item Description	Qty.	Substitute	Note
1	941200300002		Label	1		
2	941200200038		Label	1		
2	941200200039		Label	1		
3	941200300001		Label	2		
4	941200300003		Label	1		
5	941200100009		Label	1		
6	941200100012		Label	1		
7	941200100013		Label	1		
8	941200100011		Label	1		
9	941200100010		Label	1		
10	505647020002		Truck data plate	1		

Appendix

01 Hydraulic Circuit Diagram (509046045501)

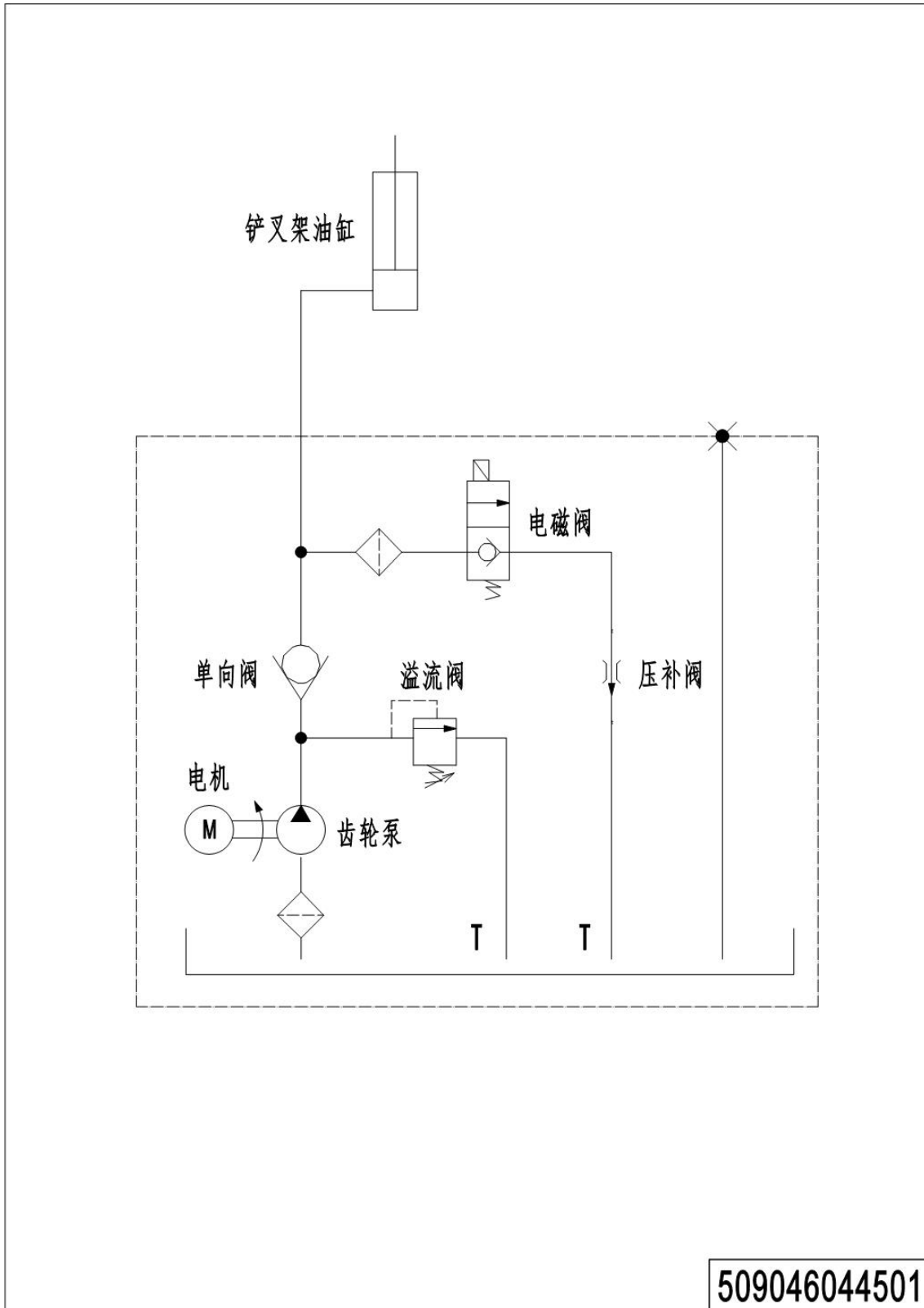

02 Electrical Circuit Diagram, F2A +1220C (509046045501)

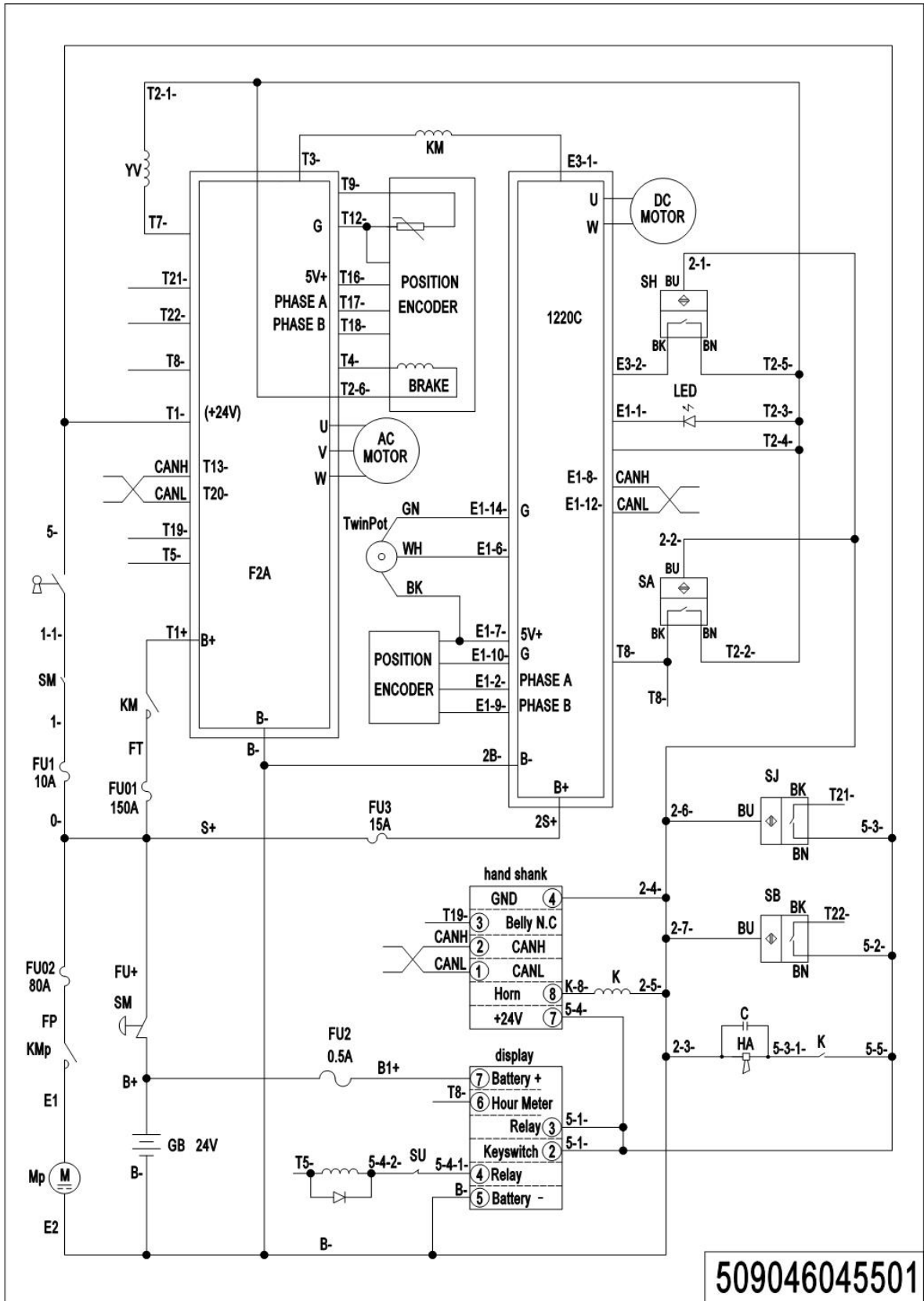

03 Electrical Circuit Diagram, 1232E+Li (509046045502)

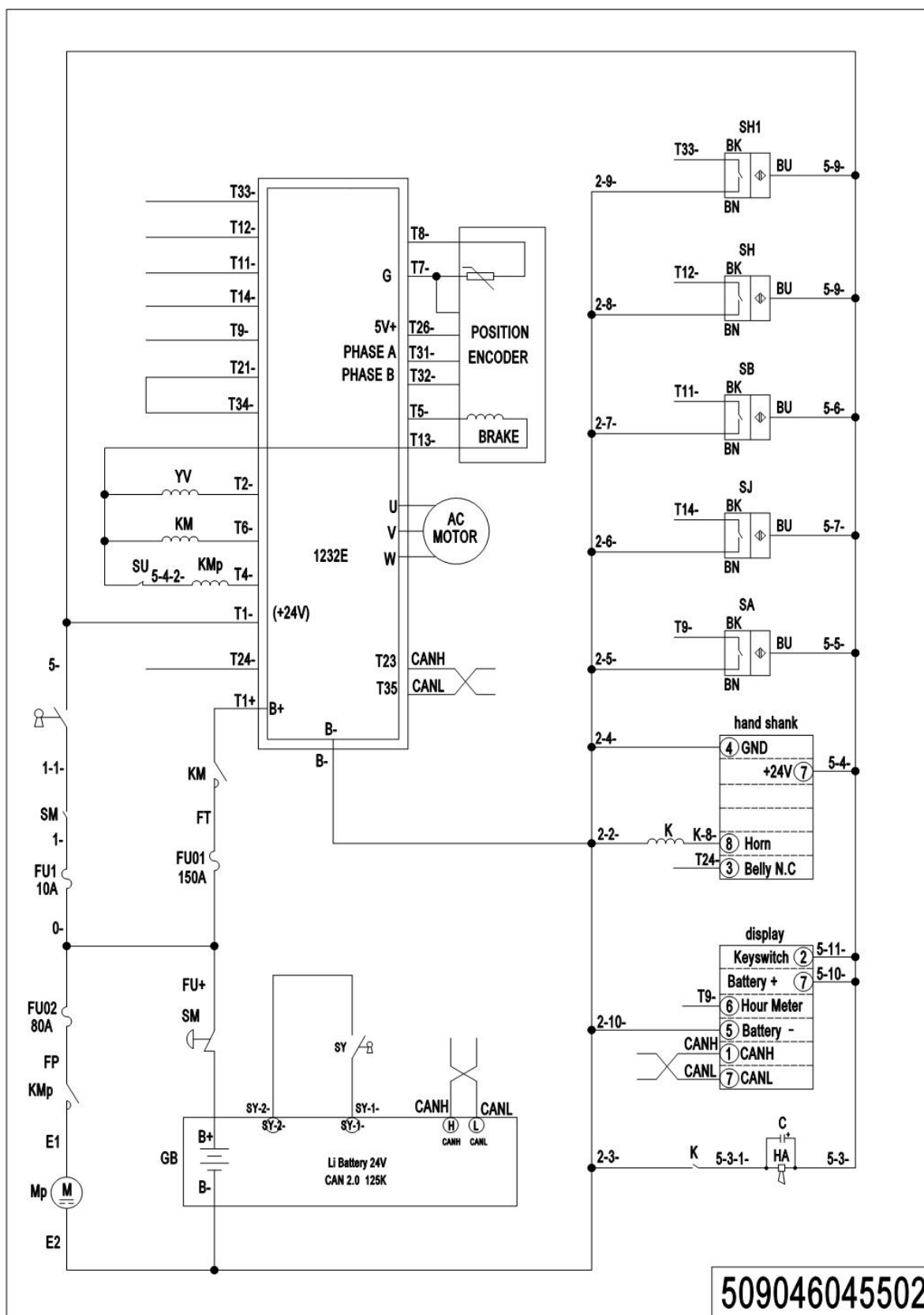

509046045502

04 Electrical Circuit Diagram, QT (509046045503)

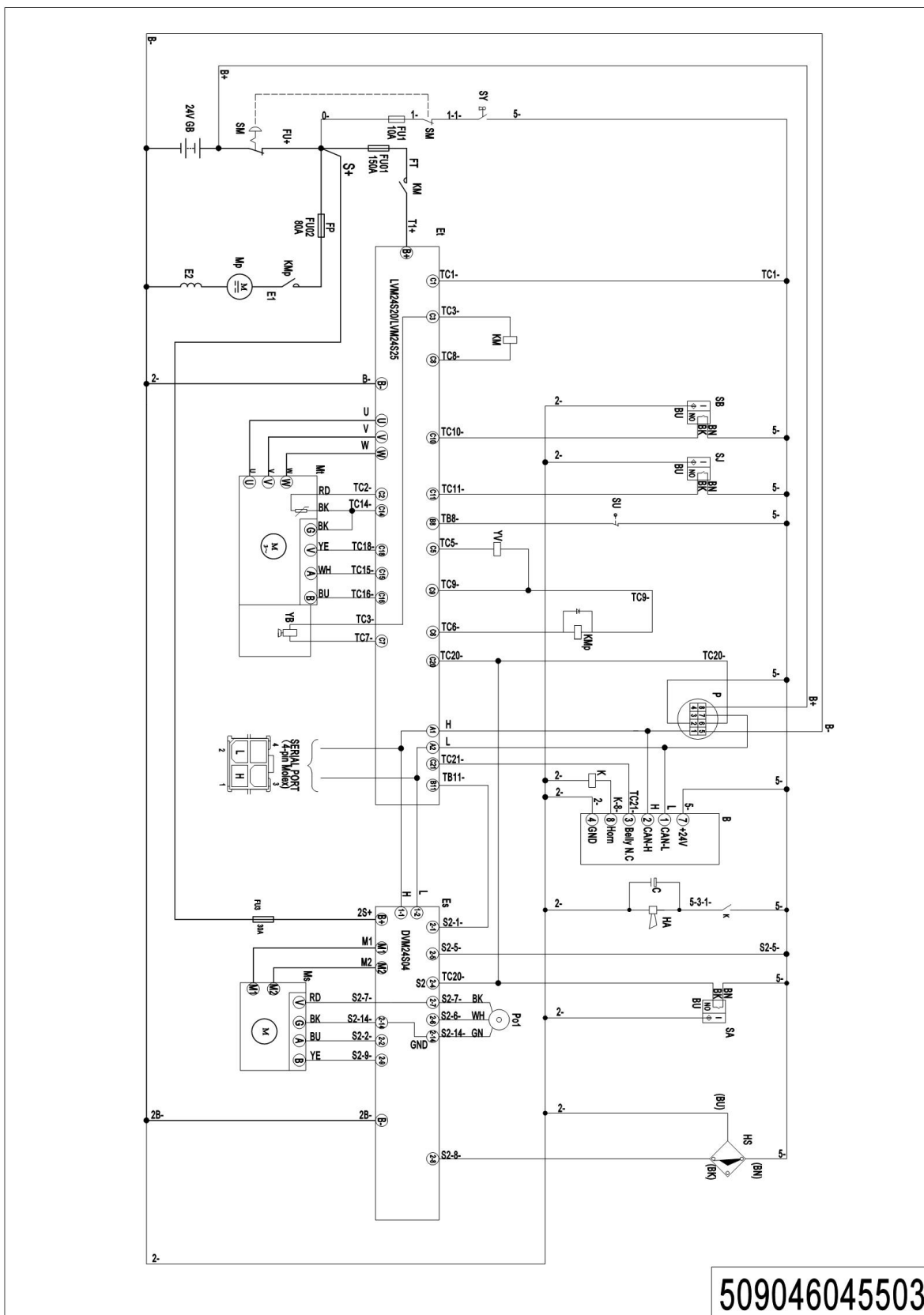

509046045503

05 Electrical Circuit Diagram, QT+Li (509046045504)

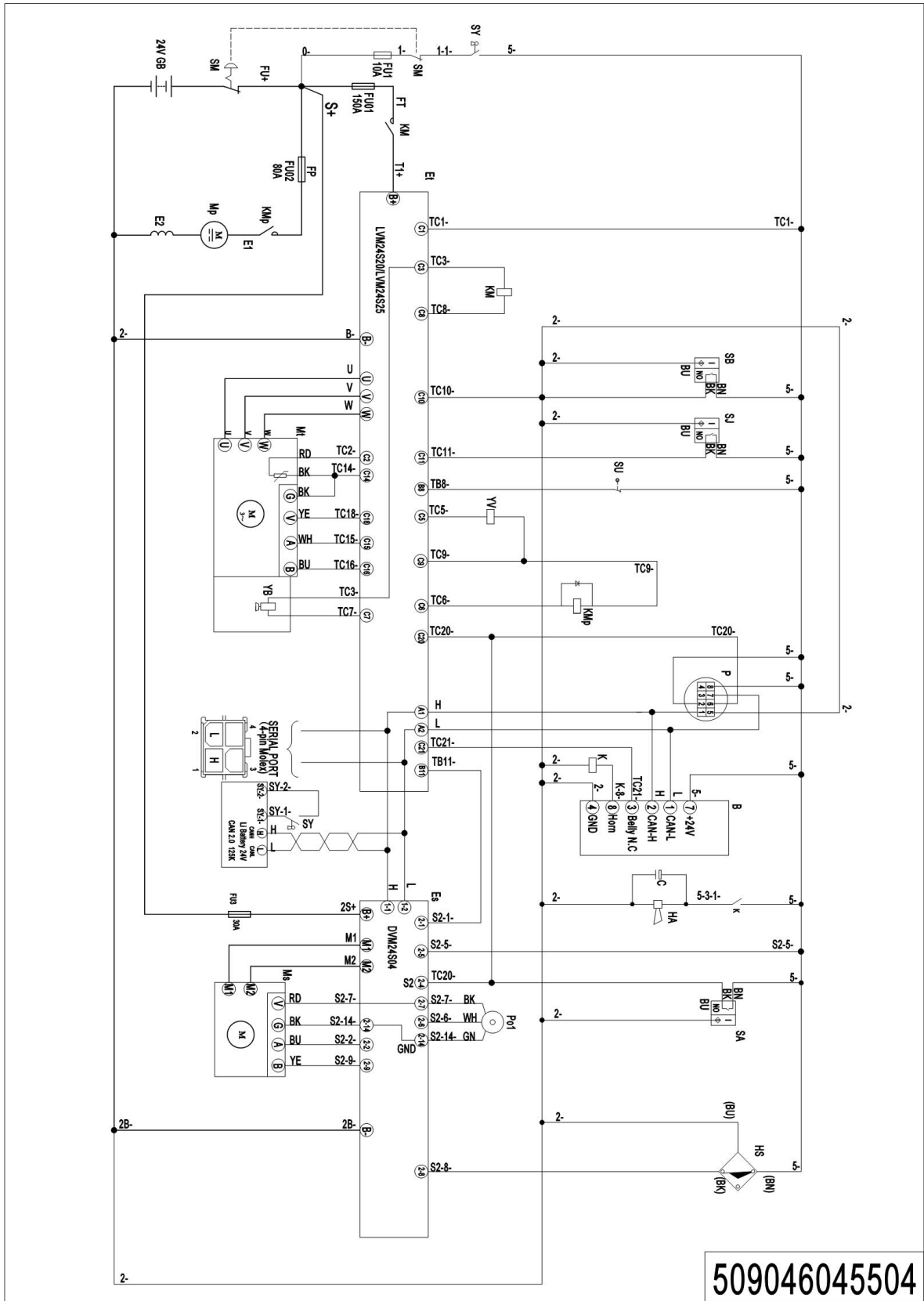

509046045504

06 Electrical Circuit Diagram, 1232E+1220C+ Fixed (509546045501)

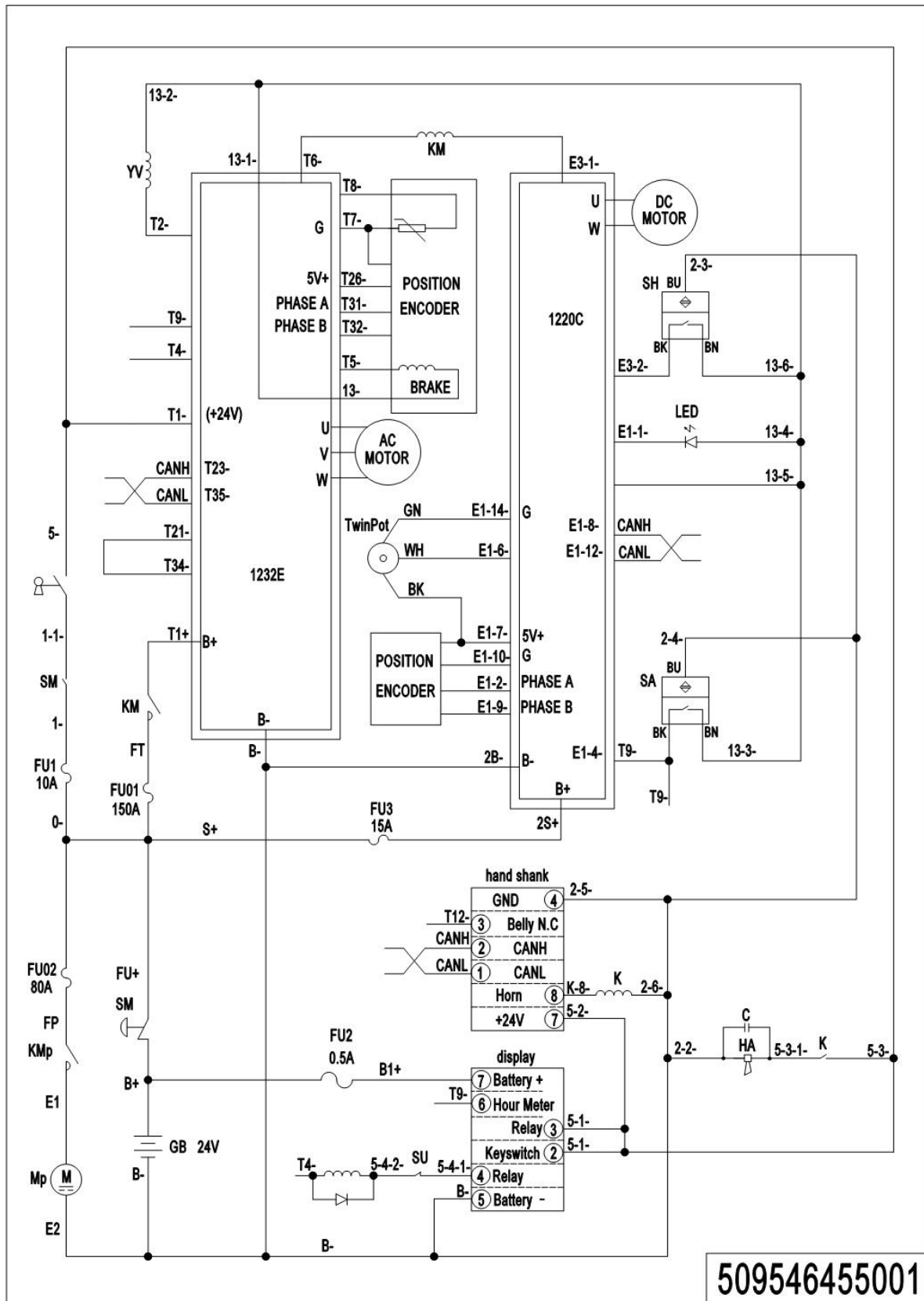

509546455001

07 Electrical Circuit Diagram, 1232E+1220C+ Foldable (509546045502)

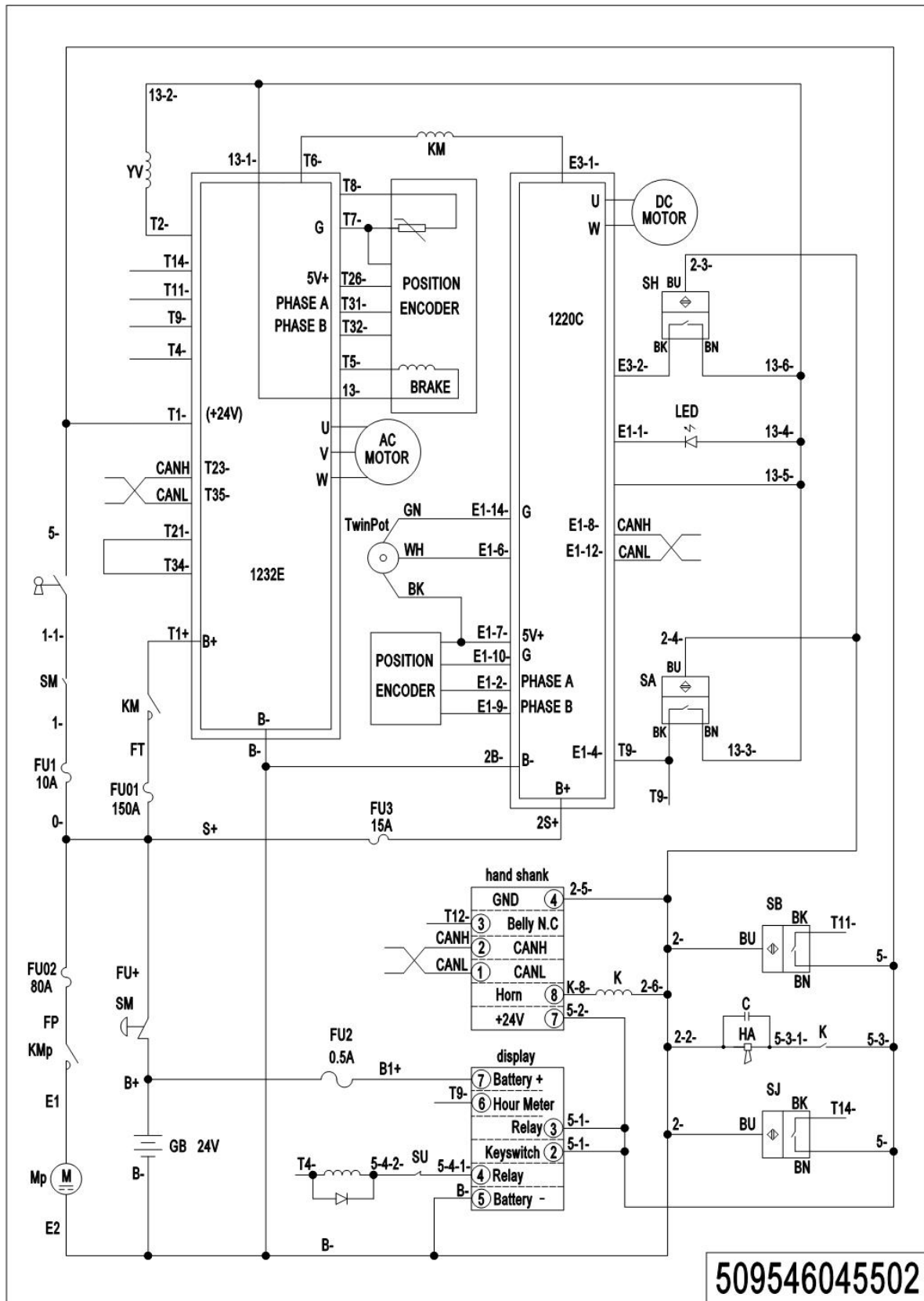

509546045502

08 Electrical Circuit Diagram, 1232E+1220C+ Fixed +Li(509546045503)

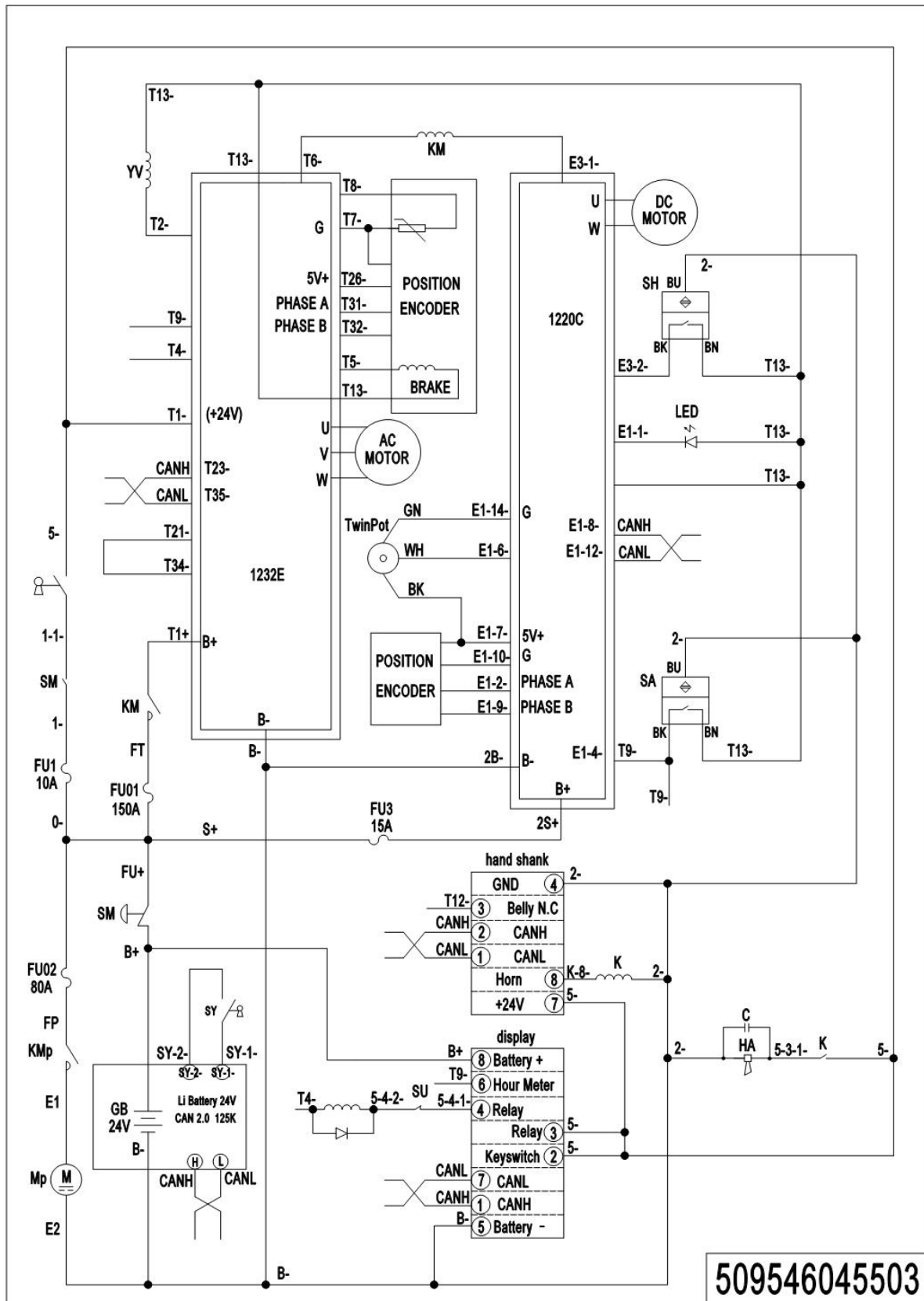

509546045503

09 Electrical Circuit Diagram, 1232E+1220C+ Foldable +Li(509546045504)

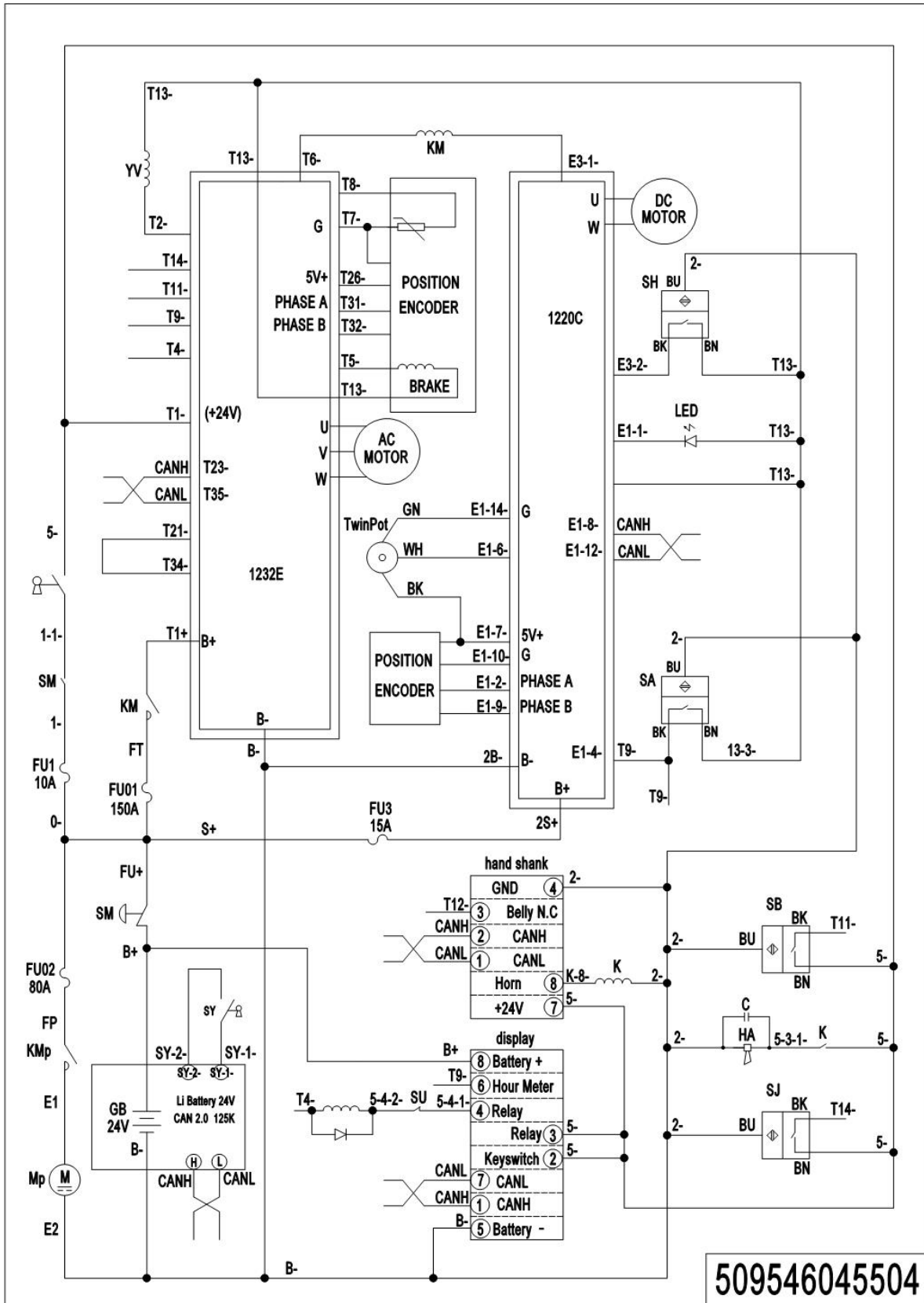

10 Consumable Parts List

No.	Item Code	Item Description	Qty.	Chapter/ Section/ Number
1	940500200010	Bushing	12	Chapter 1/01/1 Chapter 1/03/15 Chapter 1/05/15
2	940500100027	Bushing	12	Chapter 1/01/15 Chapter 1/03/17 Chapter 1/05/17
2	940500100027	Bushing	2	Chapter 4/01/6
3	940500100019	Bushing	6	Chapter 2/01/15 Chapter 2/03/15 Chapter 4/01/7
4	940500200007	Bushing	4	Chapter 3/01/32 Chapter 3/03/27
5	940500100017	Bushing	4	Chapter 3/01/35 Chapter 3/03/30
6	940500100012	Bushing	8	Chapter 4/01/14 Chapter 5/03/4
7	940500200002	Bushing	2	Chapter 5/01/8
8	940500200003	Bushing	2	Chapter 5/03/6
9	940500200002	Bushing	2	Chapter 5/04/10
10	940500100002	Bushing	4	Chapter 5/05/13
11	940500200008	Bushing	2	Chapter 6/04/11 Chapter 6/06/9 Chapter 7/02/3
12	920100100007	Fuse	1	Chapter 6/08/5 Chapter 6/09/5 Chapter 6/10/5Chapter 6/11/7
13	920100100008	Fuse	1	Chapter 6/11/9
14	920100100004	Fuse	1	Chapter 6/08/6 Chapter 6/09/6 Chapter 6/10/6
15	920100200002	Fuse	1	Chapter 6/08/9 Chapter 6/09/9 Chapter 6/10/9